



# Operation **Manual**

**Goodrive300-01A** Series VFD  
for Air Compressor



## Preface

Goodrive300-01A series variable-frequency drive (VFD) for air compressors (hereinafter referred to as GD300-01A VFD) is designed and optimized based on Goodrive300-01 to be applied in synchronous/asynchronous air compressor for optimal control performance.

GD300-01A VFD carries the air compressor-specific control logic to connect to various signals of the air compressor directly e.g. emergency-stop, pressure and temperature signals, fan transformer and fault signals. It can realize control over solenoid valve and provide 24V power to HMI. It also carries Modbus communication interface to fit the HMI without external controller or PLC, simplifying the electrical design while realizing excellent variable-frequency control.

GD300-01A VFD has undergone compatibility test with multiple mainstream motor or master manufacturers based on the application features and actual needs of air compressor industry. It adopts dedicated PID and unique flux-weakening design to enable the air compressor to start quickly and run smoothly with max driving frequency reaching 400Hz and above. Through high-power density design and compact structure, it simplifies commissioning procedures and downgrades product size. It adopts independent air duct, heavy-load and high power factor design to cope with challenging field and grid environment.

GD300-01A VFD in the range of 7.5–15kW supports the built-in contactor units, low-frequency transformer and low-frequency fan. It can provide 220V/110V power to supply the solenoid valve (hereinafter referred to as GD300-01A single VFD integrated machine) and act as the extended application of the small power of Goodrive300-21 dual VFD integrated machine, thus satisfying diversified application needs of integrated machine.

Read this manual carefully before installation to ensure GD300-01A VFD can be installed and operated correctly to give full play to its excellent performance.

If the end user is a military unit or the product is used for weapon manufacturing, please comply with relevant export control regulations in the Foreign Trade Law of the People's Republic of China, and complete necessary formalities.

Our company reserves the right to update the information of our products.

## Contents

<b>Preface</b> .....	<b>i</b>
<b>Contents</b> .....	<b>ii</b>
<b>Chapter 1 Safety precautions</b> .....	<b>1</b>
1.1 Contents of this chapter .....	1
1.2 Definition of safety information .....	1
1.3 Warning symbols .....	1
1.4 Safety instruction .....	2
1.4.1 Shipment and installation .....	2
1.4.2 Commissioning and running .....	3
1.4.3 Maintenance and component replacement .....	3
1.4.4 Scrap treatment .....	4
<b>Chapter 2 Product overview</b> .....	<b>5</b>
2.1 Product specification .....	5
2.2 Product nameplate .....	7
2.3 Model description .....	7
2.4 Rated specifications .....	8
2.4.1 Rated specifications of single-VFD products .....	8
2.4.2 Rated value of single-VFD integrated machine .....	10
<b>Chapter 3 Wiring instruction</b> .....	<b>11</b>
3.1 Main circuit wiring and terminal description .....	11
3.1.1 Main circuit wiring diagram of single VFD .....	11
3.1.2 Main circuit wiring diagram of single-VFD integrated machine .....	12
3.1.3 Main circuit terminal diagram of single VFD .....	13
3.1.4 Main circuit terminal diagram of single-VFD integrated machine .....	17
3.2 Control circuit wiring and terminal description .....	18
<b>Chapter 4 Commissioning instruction</b> .....	<b>22</b>
4.1 Commissioning instruction for the dual-VFD air compressor .....	22
4.1.1 Wiring diagram of the dual-VFD air compressor system .....	22
4.1.2 Commissioning steps for the dual-VFD air compressor .....	22
4.2 Commissioning guidance for single-VFD air compressor .....	29
4.2.1 Wiring diagram for single-VFD air compressor system .....	29
4.2.2 Commissioning steps for single-VFD air compressor .....	30
4.3 Commissioning guidance for dual-VFD + power-frequency fan scheme .....	31
4.4 Commissioning guidance for single-VFD integrated machine .....	32
<b>Chapter 5 Function code description</b> .....	<b>34</b>
5.1 Function codes .....	34
5.2 Control logic of the air compressor .....	81
5.3 PID commissioning .....	83
5.3.1 General procedures for PID parameter settings .....	84

5.3.2 PID adjusting methods .....	85
5.4 Operating logic of blower oil pump .....	89
<b>Chapter 6 Fault information and troubleshooting .....</b>	<b>90</b>
6.1 VFD faults and solutions.....	90
6.2 Fault contents and solutions of air compressor equipment.....	95
<b>Appendix A Product dimension .....</b>	<b>99</b>
A.1 Keypad diagram .....	99
A.2 External keypad installation dimensions .....	99
A.3 Wall installation dimension .....	100
A.4 Flange installation dimension .....	104
A.5 Product weight and package dimension.....	106
A.5.1 Weight and package dimension of single-VFD product.....	106
A.5.2 Weight and package dimension of single-VFD integrated machine.....	106
<b>Appendix B External optional accessories .....</b>	<b>107</b>
B.1 RS485 LCD keypad .....	107
B.1.1 LCD keypad introduction .....	107
B.1.2 LCD keypad structure .....	109
B.1.3 RS485 communication cable .....	110
B.1.4 Setting parameters on the LCD keypad.....	111
B.1.5 Fault records .....	131
B.1.6 VFD information .....	133
B.1.7 System configuration.....	135
B.2 TC070A touch screen.....	141
B.2.1 Specifications .....	141
B.2.2 Connection terminals.....	142
B.2.3 Wiring description .....	143
B.2.4 Cable description.....	144
B.2.5 Installation dimensions and description .....	145
B.3 IoT module .....	146
B.3.1 Product overview .....	146
B.3.2 Installation dimensions.....	150
B.3.3 Operational guide .....	151
B.3.4 Ordering information.....	151
B.4 Fan control protector .....	152
B.4.1 Model instruction.....	152
B.4.2 Rated specifications .....	152
B.4.3 Terminal description.....	152
B.4.4 Wiring description and commissioning instruction.....	154
B.5 Filter .....	155
B.6 Reactor .....	156
<b>Appendix C Current transformer of the fan .....</b>	<b>157</b>

---

C.1 Current transformer model selections .....	157
C.2 Wiring of current transformer of the fan .....	157
C.3 Parameter setup of current transformer of the fan .....	158
<b>Appendix D Communication protocol .....</b>	<b>159</b>
D.1 Application mode .....	159
D.2 RTU command code and communication data .....	159
D.2.1 Command code: 03H, read N words ( $N \leq 16$ ).....	159
D.2.2 Command code: 06H, write one word.....	159
D.2.3 Command code: 08H, diagnosis function.....	159
D.2.4 Definition of data address.....	160
D.2.5 Error message response .....	164
<b>Appendix E Common EMC problems and troubleshooting.....</b>	<b>166</b>
E.1 Interference problems of meter switches and sensors .....	166
E.2 485 communication interferences .....	166
E.3 Unstoppable or shimmering indicator caused by coupling of motor cable.....	167
E.4 Leakage current and residual current device (RCD) .....	168
E.5 Problem of charged device shell .....	169

## Chapter 1 Safety precautions

### 1.1 Contents of this chapter

Read this manual carefully and follow all safety precautions before moving, installing, operating and servicing the VFD. Should the safety precautions be ignored, physical injury or death may occur, or damage may occur to the devices.

If any physical injury or death or damage to the devices occurs due to neglect of the safety precautions in the manual, our company will not be responsible for any damages and we are not legally bound in any manner.

### 1.2 Definition of safety information

**Danger:** Serious physical injury or even death may occur if related requirements are not followed









**Warning:** Physical injury or damage to the devices may occur if related requirements are not followed

**Note:** Procedures which must be taken to ensure proper operation.





**Qualified electricians:** People working on the equipment should take part in professional electrical and safety training, receive related certification and be familiar with all steps and requirements related to installation, commissioning, operation and maintenance of the equipment to prevent any emergency.

### 1.3 Warning symbols

Warnings caution you about conditions which can result in serious injury or death and/or damage to the equipment, and advice on how to avoid the danger. Following warning symbols are used in this manual:

Sign	Name	Description	Abbreviation
 Danger	Danger	Serious physical injury or even death may occur if related requirements are not followed.	
 Warning	Warning	Physical injury or damage to the devices may occur if related requirements are not followed.	
 No touch	Electrostatic discharge	Damage to the PCBA board may occur if related requirements are not followed.	
 Hot	Hot side	The VFD base may become hot. Do not touch.	
Note	Note	Procedures which must be taken to ensure proper operation.	Note

### 1.4 Safety instruction

	<ul style="list-style-type: none"> <li>● Only well-trained and qualified personnel are allowed to operate on the VFD.</li> <li>● Do not carry out wiring, inspection or component replacement when the power supply is applied. Ensure all the input power supplies are disconnected before wiring and inspection, and always wait for at least the time designated on the VFD or until the DC bus voltage is less than 36V. The waiting time is shown as below.</li> </ul> <table border="1" style="margin-left: auto; margin-right: auto;"> <thead> <tr> <th colspan="2" style="text-align: center;">VFD model</th> <th style="text-align: center;">Minimum waiting time</th> </tr> </thead> <tbody> <tr> <td style="text-align: center;">380V</td> <td style="text-align: center;">7.5kW–315kW</td> <td style="text-align: center;">5 minutes</td> </tr> </tbody> </table>	VFD model		Minimum waiting time	380V	7.5kW–315kW	5 minutes
VFD model		Minimum waiting time					
380V	7.5kW–315kW	5 minutes					
	<ul style="list-style-type: none"> <li>● Do not refit the VFD unless authorized; otherwise, fire, electric shock or other injuries may occur.</li> </ul>						
	<ul style="list-style-type: none"> <li>● The base of the radiator may become hot during running. Do not touch to avoid hurt.</li> </ul>						
	<ul style="list-style-type: none"> <li>● The electrical parts and components inside the VFD are electrostatic-sensitive. Take proper measurements to avoid electrostatic discharge during related operation.</li> </ul>						

#### 1.4.1 Shipment and installation

	<ul style="list-style-type: none"> <li>● Install the VFD on fire-retardant material and keep the VFD away from combustible materials.</li> <li>● Connect the optional brake parts (brake resistors, brake units or feedback units) according to the wiring diagram.</li> <li>● Do not operate on the VFD if there is any damage or components loss to the VFD.</li> <li>● Do not touch the VFD with wet items or body; otherwise, electric shock may occur.</li> </ul>
---	--

**Note:**

- ✧ Select appropriate moving and installing tools to ensure a safe and normal running of the VFD and avoid physical injury or death. For physical safety, the installer must take mechanical protective measures, such as wearing exposure shoes and working uniforms.
- ✧ Ensure the VFD suffers no physical impact or vibration during moving and installation.
- ✧ Do not carry the VFD by its front cover only as the cover may fall off.
- ✧ Installation site must be away from children and other public places.
- ✧ When the altitude exceeds 1000m, derate by 1% for every increase of 100m. When the altitude exceeds 3000m, consult the local INVT dealer or office for details.
- ✧ The application environment should be proper and appropriate.
- ✧ Prevent the screws, cables and other conductive objects from falling into the VFD.
- ✧ The leakage current of the VFD may be above 3.5mA during operation. Ground with proper

techniques and ensure the grounding resistor is less than  $10\Omega$ . The conductivity of PE grounding conductor is the same as that of the phase conductor (with the same cross sectional area). For models of higher than 30 kW, the cross sectional area of the PE grounding conductor can be slightly less than the recommended area.

- ◇ R, S and T are the power supply input terminals, while U, V and W are the output motor terminals. Connect the input power cables and motor cables correctly; otherwise, damage to the VFD may occur.

#### 1.4.2 Commissioning and running

	<ul style="list-style-type: none"> <li>● Disconnect all power supplies of the VFD before terminal wiring and wait for at least the designated time after disconnecting the power supply.</li> <li>● High voltage is present inside the VFD during running. Do not carry out any operation on the VFD except for keypad setting.</li> <li>● The VFD may start up by itself when P01.21=1. Do not get close to the VFD and motor.</li> <li>● The VFD cannot be used as “Emergency-stop device”</li> <li>● The VFD cannot be used to brake the motor suddenly. A mechanical brake device must be installed.</li> </ul>
---	---

#### Note:

- ◇ Do not switch on or off the input power supply of the VFD frequently.
- ◇ For VFDs that have been stored for a long time, check and fix the capacitance and try pilot run first before actual application.
- ◇ Close the front cover before running the VFD; otherwise, electric shock may occur.



#### 1.4.3 Maintenance and component replacement

	<ul style="list-style-type: none"> <li>● Only well-trained and qualified professionals are allowed to carry out maintenance, inspection, and component replacement of the VFD.</li> <li>● Disconnect all power supplies of the VFD before terminal wiring. Wait for at least the time designated on the VFD after disconnecting the power supply.</li> <li>● Take proper measures to prevent screws, cables and other conductive objects from falling into the VFD during maintenance and component replacement.</li> </ul>
---	---

#### Note:

- ◇ Select proper torque to tighten the screws.
- ◇ Keep the VFD and its parts and components away from combustible materials during maintenance and component replacement.
- ◇ Do not carry out any insulation voltage-endurance test on the VFD or measure the control circuit of the VFD by megameter.
- ◇ Take anti-static measures on internal parts during maintenance and component replacement.

**1.4.4 Scrap treatment**

	<ul style="list-style-type: none"><li>● There are heavy metals in the VFD. Treat with it as industrial effluent.</li></ul>
	<ul style="list-style-type: none"><li>● When the life cycle ends, the product should enter the recycling system. Dispose of it separately at an appropriate collection point instead of placing it in the normal waste stream.</li></ul>

## Chapter 2 Product overview

### 2.1 Product specification

Category	Function	Specification
Power input	Input voltage of the VFD (V)	3PH 380V (-15%)–440V (+10%) 3PH 220V (-15%)–240V (+10%)
	Rated input current (A)	Refer to 2.4 "Rated specifications".
	Rated input frequency (Hz)	50Hz or 60Hz, allowed range: 47–63Hz
	Power	> 97%
	Power factor	0.9
Frequency -conversion power output	Output voltage(V)	Equal to input voltage, error ratio: less than 5%
	Rated output current (A)	Refer to 2.4 "Rated specifications".
	Rated output power (kW)	Refer to 2.4 "Rated specifications".
	Output frequency(Hz)	0–400Hz
Power -frequency fan output (single VFD integrated machine)	Output voltage (V)	Equal to input voltage, error ratio: less than 1%
	Rated output current (A)	Refer to 2.4 "Rated specifications".
	Rated output power (kW)	Refer to 2.4 "Rated specifications".
	Output frequency (Hz)	Equal to input frequency, error ratio: less than 1%
Power output	+24VDC power	24W
	220VAC/110VAC	15W (for single VFD integrated machine)
Running control performance	Control mode	Open loop vector, space voltage vector
	Speed regulation ratio	Asynchronous motor: 1:200 (SVC); Synchronous motor: 1:20 (SVC)
	Speed control precision	±0.2% (SVC)
	Speed fluctuation	±0.3% (SVC)
	Torque response	<20ms (SVC)
	Starting torque	Asynchronous motor: 0.25Hz 150% (SVC) Synchronous motor: 2.5Hz 150% (SVC)
	Frequency reference mode	PID control, Modbus communication, P1- and P2- analog input, keypad digital input
	Overload capacity	1min at 150%
	Dedicated function	Sleep and wake-up function, constant pressure control, constant temperature control, parts maintenance, phase sequence detection, fan overload protection
	Analog pressure input	Two 4–20mA/0–1.6MPa inputs
	Analog temperature input	Two analog temperature inputs; resolution rate: 1°C; Range: -20°C–150°C; precision error: 3°C
	Digital input	Five normal inputs, max frequency: 1kHz

Category	Function	Specification
	Digital output	Two relay outputs (NO) 250VAC/3A; one convertible relay output 250VAC/3A
	Fault protection function	Over 30 kinds of fault protection functions: overcurrent, overvoltage, undervoltage, overtemperature, phase loss, overload, fan current imbalance, etc.
	Fan protection function	Overload protection: 1 min at 120% overload; 48s at 130% overload; 24s at 150% overload; 8s at 160% overload; 5s at 200% overload; 1s at 300% overload
		Current imbalance protection: when any two phases differ from each other by 60–75%, stop at fault, action time ≤5s
		Output short-circuit protection: the protection can be implemented by using the internal fuse (applicable to single VFD integrated machine only)
	Solenoid valve port protection	Output short-to-ground protection: the protection can be implemented by using the internal fuse (applicable to single VFD integrated machine only)
220V/110V output short-circuit protection: the protection can be implemented by using the internal fuse (applicable to single VFD integrated machine only)		
485 communication	One 485 communication (three terminal interfaces)	
Others	Installation mode	Wall installation, flange installation
	Temperature of running environment	-10–50°C, derating is required if the temperature exceeds 40°C; derate by 1% for every increased 1°C
	Protection level	IP20
	Pollution level	Level 2
	Cooling mode	Forced-air cooling
	DC reactor	DC reactors are optional parts for 7.5–11kW VFD models and can be built into the models; DC reactors have been built into 15–110kW models as standard configuration; DC reactors are optional parts for 132–315kW



Sign	Description	Content
③	Voltage class	2: AC 3PH 220V(-15%)–240V(+10%) 4: AC 3PH 380V(-15%)–440V(+10%)
④	Power-frequency fan/ Built-in transformer	Empty: VFD dedicated for single-VFD air compressor  Single-VFD air compressor integrated machine C: Built-in contactor unit, supporting power-frequency fan output T: Built-in power-frequency transformer, providing 220V/110V power supply

## 2.4 Rated specifications

### 2.4.1 Rated specifications of single-VFD products

#### AC 3PH 220V(-15%)–240V(+10%)

Product model	Output power (kW)	Input current (A)	Output current (A)	Installation dimension description
GD300-01A-7R5G-2	7.5	32	30	Same as GD300-01A-015G-4
GD300-01A-011G-2	11	44	42	Same as GD300-01A-022G-4
GD300-01A-015G-2	15	58	55	Same as GD300-01A-030G-4
GD300-01A-018G-2	18.5	72	70	Same as GD300-01A-037G-4
GD300-01A-022G-2	22	87	80	Same as GD300-01A-045G-4
GD300-01A-030G-2	30	106	110	Same as GD300-01A-055G-4
GD300-01A-037G-2	37	140	130	Same as GD300-01A-075G-4
GD300-01A-045G-2	45	170	160	Same as GD300-01A-090G-4
GD300-01A-055G-2	55	202	200	Same as GD300-01A-110G-4
GD300-01A-075G-2	75	310	270	Same as GD300-01A-160G-4
GD300-01A-090G-2	90	345	320	Same as GD300-01A-185G-4
GD300-01A-110G-2	110	385	380	Same as GD300-01A-200G-4

Product model	Output power (kW)	Input current (A)	Output current (A)	Installation dimension description
GD300-01A-132G-2	132	485	450	Same as GD300-01A-250G-4
GD300-01A-160G-2	160	545	540	Same as GD300-01A-280G-4
GD300-01A-185G-2	185	610	620	Same as GD300-01A-315G-4

**AC 3PH 380V(-15%)–440V(+10%)**

Product model	Output power (kW)	Input current (A)	Output current (A)
GD300-01A-7R5G-4	7.5	25	18.5
GD300-01A-011G-4	11	32	25
GD300-01A-015G-4	15	32	32
GD300-01A-018G-4	18.5	37	38
GD300-01A-022G-4	22	44	45
GD300-01A-030G-4	30	58	60
GD300-01A-037G-4	37	72	75
GD300-01A-045G-4	45	87	92
GD300-01A-055G-4	55	106	115
GD300-01A-075G-4	75	140	150
GD300-01A-090G-4	90	170	180
GD300-01A-110G-4	110	202	215
GD300-01A-132G-4	132	265	260
GD300-01A-160G-4	160	310	305
GD300-01A-185G-4	185	345	340
GD300-01A-200G-4	200	385	380
GD300-01A-220G-4	220	430	425
GD300-01A-250G-4	250	485	480
GD300-01A-280G-4	280	545	530
GD300-01A-315G-4	315	610	600
GD300-01A-350G-4	350	625	650
GD300-01A-400G-4	400	715	720
GD300-01A-500G-4	500	890	860

**Note:**

- ◇ Rated input current is the actually measured result under 380V input voltage; 7.5–11kW and 132–315kW are the actually measured results in cases where there is no DC reactor; 15–110kW is the actually measured result in cases where there is DC reactor.
- ◇ Rated output current is defined as the output current under 380V output voltage.

**2.4.2 Rated value of single-VFD integrated machine**

Model	Rated input current of the integrated machine (A)	Frequency conversion of main motor		Power frequency of the fan	
		Rated output power (kW)	Rated output current (A)	Rated output power (kW)	Rated output current (A)
GD300-01A-7R5G-4-CT	28	7.5	18.5	0.75	2.5
GD300-01A-011G-4-CT	35	11	25	0.75	2.5
GD300-01A-015G-4-CT	34	15	32	0.75	2.5

**Note:**

- ✧ Rated input current is the actually measured result under 380V input voltage without DC reactor.
- ✧ Rated output current is defined as the output current under 380V output voltage.

## Chapter 3 Wiring instruction

### 3.1 Main circuit wiring and terminal description

#### 3.1.1 Main circuit wiring diagram of single VFD

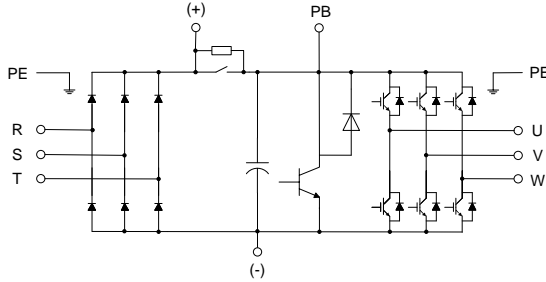

Figure 3-1 7.5kW main circuit wiring diagram

**Note:** There is brake circuit but no DC reactor for 7.5kW

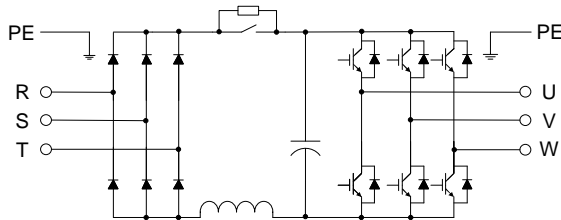

Figure 3-2 11–15kW main circuit wiring diagram

**Note:** There is optional built-in DC reactor for 11kW and standard built-in DC reactor for 15kW.

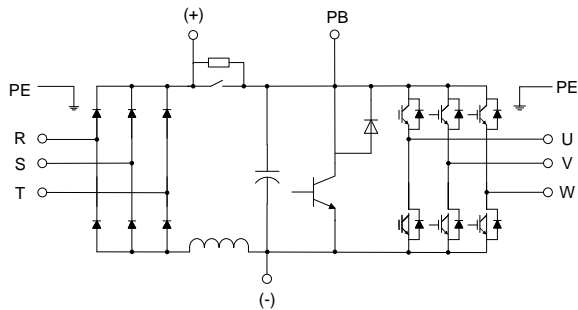

Figure 3-3 18.5–110kW main circuit wiring diagram

**Note:** There is internal brake circuit for 18.5–22kW; there is no internal brake circuit for 30–110kW; there is standard internal DC reactor for 18.5–110kW.

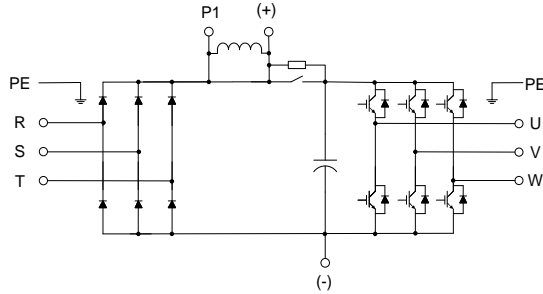

Figure 3-4 132–315kW main circuit wiring diagram

**Note:**

- ◇ DC reactors are optional parts for 132–315kW VFD models and can be externally connected.
- ◇ See Appendix B for filter and reactor model selection.

**3.1.2 Main circuit wiring diagram of single-VFD integrated machine**

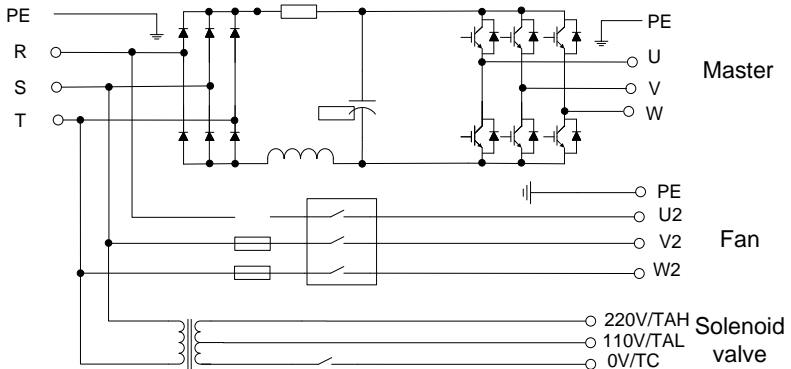

Figure 3-5 Main circuit wiring diagram for 7.5–15kW single-VFD integrated machine

**Note:** DC reactors are optional parts for 7.5–11kW VFD models and can be built into the models.

3.1.3 Main circuit terminal diagram of single VFD

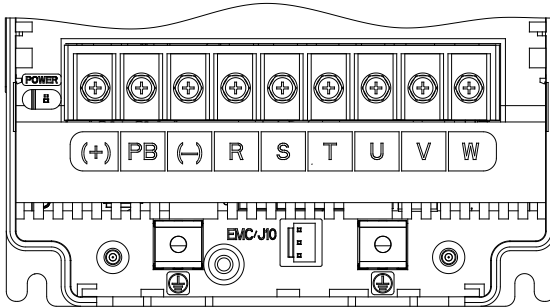

Figure 3-6 7.5kW main circuit terminal diagram

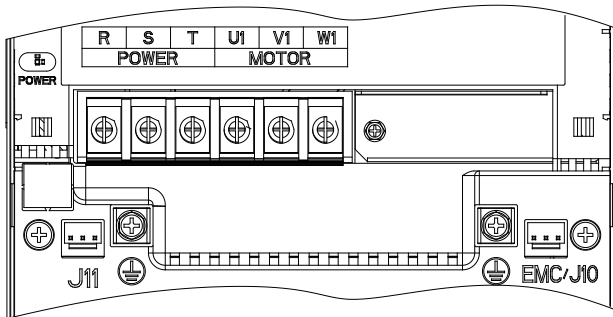

Figure 3-7 11-15kW main circuit terminal diagram

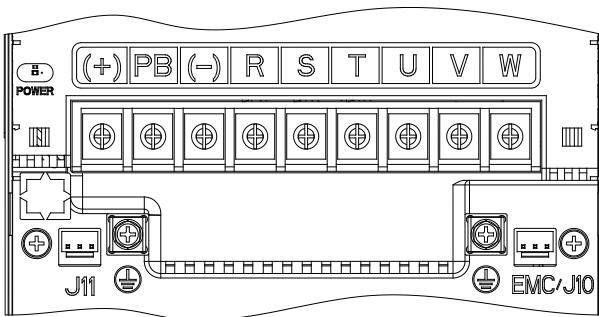

Figure 3-8 18.5-22kW main circuit terminal diagram

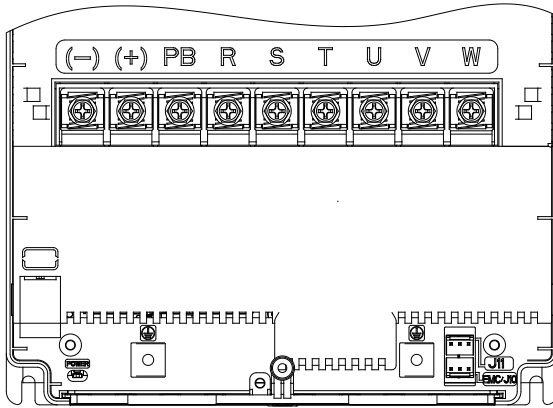

Figure 3-9 30-37kW main circuit terminal diagram

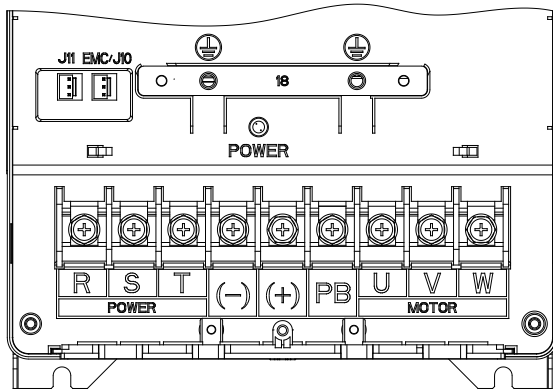

Figure 3-10 45-55kW main circuit terminal diagram

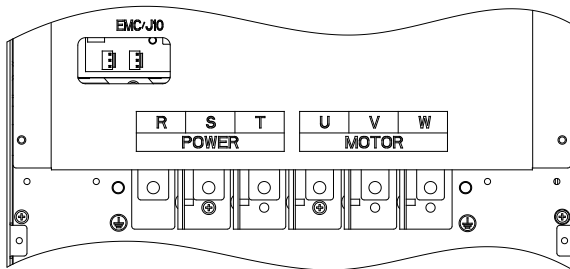

Figure 3-11 75kW main circuit terminal diagram

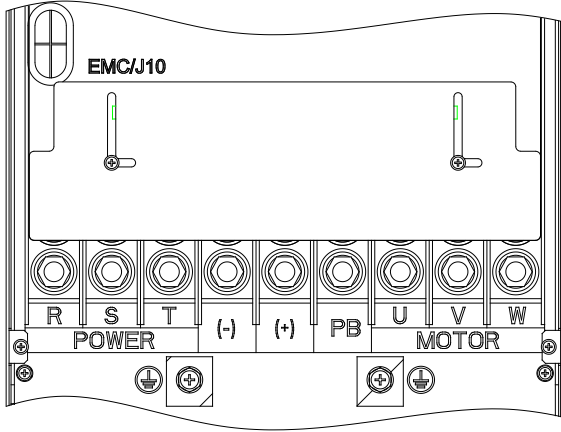

Figure 3-12 90–110kW main circuit terminal diagram

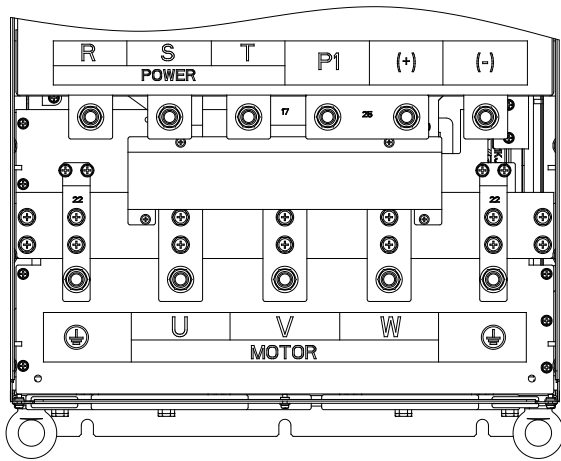

Figure 3-13 132–200kW main circuit terminal diagram

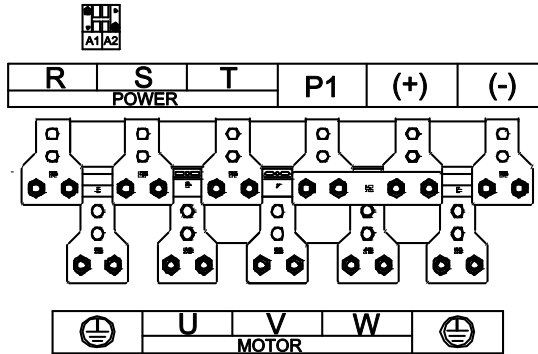

Figure 3-14 220–315kW main circuit terminal diagram

Table 3-1 Screw specification and torque of main circuit terminals of a single VFD

Power range (kW)	Terminal screw specification	Torque of torque driver (N·m)
7.5–15	M5	2.5
18.5–37	M6	3.5
45–110	M8	10
132–200	M12	35
220–315	M12	35

Table 3-2 Main circuit terminal description of a single VFD

Terminal sign	Terminal name			Terminal function
	11–15kW	7.5kW and 18.5–110kW	132kW and above	
R, S, T	Main circuit power input			3PH AC input terminal, connected to the grid
P1	None		DC reactor terminal 1	P1, (+) connect to DC reactor terminal
(+)	None	Reserved	DC reactor terminal 2	
(-)	None	Reserved	Reserved	
PB	None	Reserved	None	
U, V, W	VFD output			3PH AC output terminal, connected to the motor
⊕	Ground terminal for safety protection			Each machine must be grounded. The grounding is implemented through the two PE terminals on the machine, and the grounding resistance is less than 10Ω.

3.1.4 Main circuit terminal diagram of single-VFD integrated machine

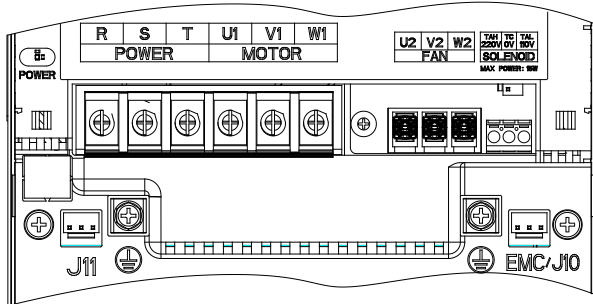

Figure 3-15 Main circuit terminal diagram of 7.5–15kW single-VFD integrated machine

Table 3-3 Screw specification and torque of main circuit terminals of 7.5kW–15kW single-VFD integrated machine

Power range (kW)	Terminal screw specification	Torque of torque driver (N·m)
7.5–15	M5	2.5

Table 3-4 Main circuit terminal description of single VFD integrated machine

Terminal sign		Function
POWER	R, S, T	3PH AC input terminal, connected to the grid
MOTOR	U1, V1, W1	3PH AC output terminal, connected to the air compressor main motor
FAN	U2, V2, W2	3PH AC output terminal, connected to the fan
SOLENOID	220V/TAH, 110V/TAL, 0V/TC	220V/110V output terminal, connected to solenoid valve coil <b>Note:</b> 1. Max. output power of internal power-frequency transformer: 15W 2. When you choose the solenoid valve with 220V coil, connect the solenoid coil to 220V and 0V connecting terminals; 3. When you choose the solenoid valve with 110V coil, connect the solenoid coil to 110V and 0V connecting terminals.
		Each machine must be grounded. The grounding is implemented through the two PE terminals on the machine, and the grounding resistance is less than 10Ω.

**Note:** Do not connect the connecting terminal of solenoid valve to other external loads; if the power of solenoid valve coil exceeds 15W, the power-frequency transformer inside the integrated machine will need to be customized or connected to external 220V/110V power independently.

### 3.2 Control circuit wiring and terminal description

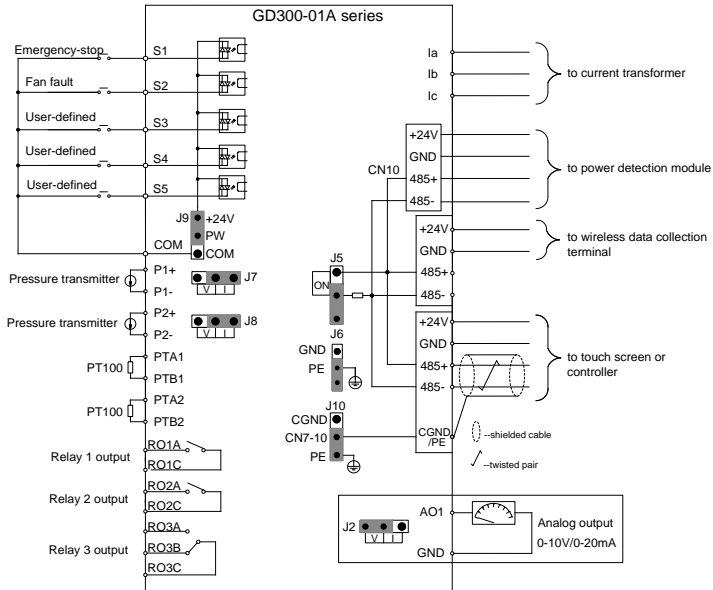

Figure 3-16 Control circuit wiring diagram

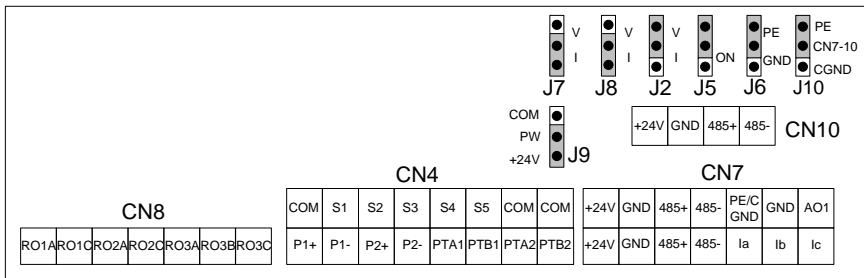

Figure 3-17 Control circuit terminal diagram

Table 3-5 User terminal description of control circuit

Category	Sign	Name	Function
Power	+24V	+24v power	Provide +24V±5% power to the external, max. output current: 1A Can be used to power up GPRS, touch screen and power detection module
	GND	+24V, AO1, Ia, Ib, Ic reference ground	+24V, AO, Ia, Ib, Ic reference ground

Category	Sign	Name	Function
PT100 signal input	PTA1	Analog temperature signal 1	1. Resolution rate: 1°C 2. Range: -20°C–150°C 3. Detection precision: 3°C
	PTB1		
	PTA2	Analog temperature signal 2	
	PTB2		
Pressure signal input	P1+	Analog pressure signal 1	1. Input range: current/voltage is optional, 0–20mA/0–10V; of which P1 is switched via J7 and P2 via J8 2. Input impedance: 20kΩ during voltage input; 500Ω during current input 3. Resolution rate: 5mV (minimum value) 4. Error: ±1%, 25°C
	P1-		
	P2+	Analog pressure signal 2	
	P2-		
Analog output	AO1	Analog output signal 1	1. Output range: 0–10V voltage or 0–20mA current; voltage or current output is set by the jumper; AO1 is switched via J2. 2. Error: ±1%, 25°C
Digital input	S1	Digital input 1	1. Internal impedance: 3.3kΩ 2. 12–30V voltage input is acceptable 3. Max. input frequency: 1kHz
	S2	Digital input 2	
	S3	Digital input 3	
	S4	Digital input 4	
	S5	Digital input 5	
	COM	Digital reference ground	
Communication	485+, 485-	485 communication	485 communication terminal, adopting the Modbus RTU protocol
	PE/CGND		PE: When selecting PE through J10, it can be used as the connecting terminal of 485 communication shielded cable; CGND: When selecting CGND through J10, it can be used as the connecting terminal of 485 communication shielded cable
Relay output	RO1A	NO contact of relay 1	1. Contact capacity: 3A/AC250V, 1A/DC30V 2. Cannot be used as high-frequency switch output <b>Note:</b> RO1 port of single-VFD integrated machine is connected to solenoid coil port by default.
	RO1C	Public contact of relay 1	
	RO2A	NO contact of relay 2	
	RO2C	Public contact of relay 2	
	RO3A	NO contact of relay 3	
	RO3B	NC contact of relay 3	
RO3C	Public contact of relay 3		
Current input	Ia	A-phase current input of the fan	1 Range: 0–40A 2. Error: ±3%, 25°C

Category	Sign	Name	Function
	lb	B-phase current input of the fan	3. Input impedance: 50Ω <b>Note:</b> See <i>Appendix C</i> for model selection of current transformer.
	lc	C-phase current input of the fan	
Jumper terminal	J7	P1-Analog signal selection terminal	I corresponds to current signal, V corresponds to voltage signal, and the default is current input signal.
	J8	P2-Analog signal selection terminal	I corresponds to current signal, V corresponds to voltage signal, and the default is current input signal.
	J2	AO1 analog output signal selection terminal	I corresponds to current signal, V corresponds to voltage signal, and the default is voltage output signal.
	J5	Connection terminal of 485 communication terminal resistor	ON corresponds to terminal resistor. ON is not connected to terminal resistor by default.
	J6	Short-connect terminal between PE and GND	No short connection by default
	J9	Internal/external power selection terminal	PW is connected to +24V by default. See Figure 3-19 and Figure 3-20.
	J10	PE/CGND selection terminal	RS485 communication adopts non-isolation mode, and CN7-10 is short connected to PE by default. See Figure 3-18.

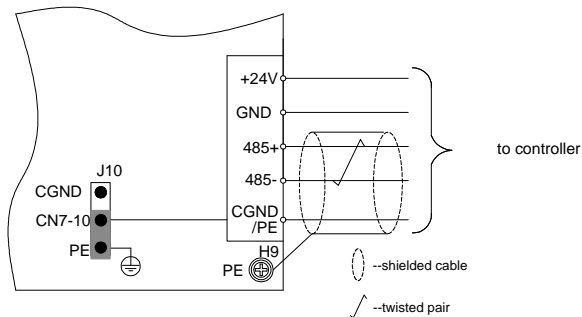

Figure 3-18 485 communication wiring diagram (non-isolation mode)

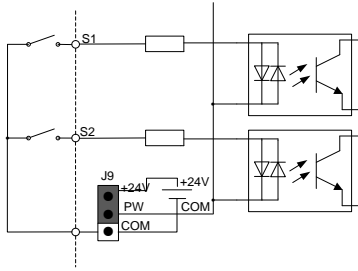

Figure 3-19 Internal power (NPN mode)

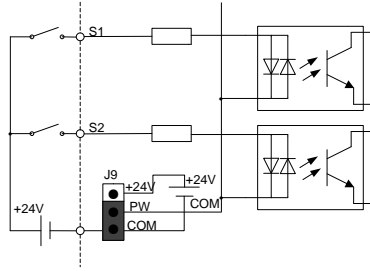

Figure 3-20 External power (PNP mode)

When the digital input uses internal +24V, set J9 according to Figure 3-19, and short +24V to PW.  
When digital input uses external +24V, set J9 according to Figure 3-20, and short COM to PW.

## Chapter 4 Commissioning instruction

### 4.1 Commissioning instruction for the dual-VFD air compressor

#### 4.1.1 Wiring diagram of the dual-VFD air compressor system

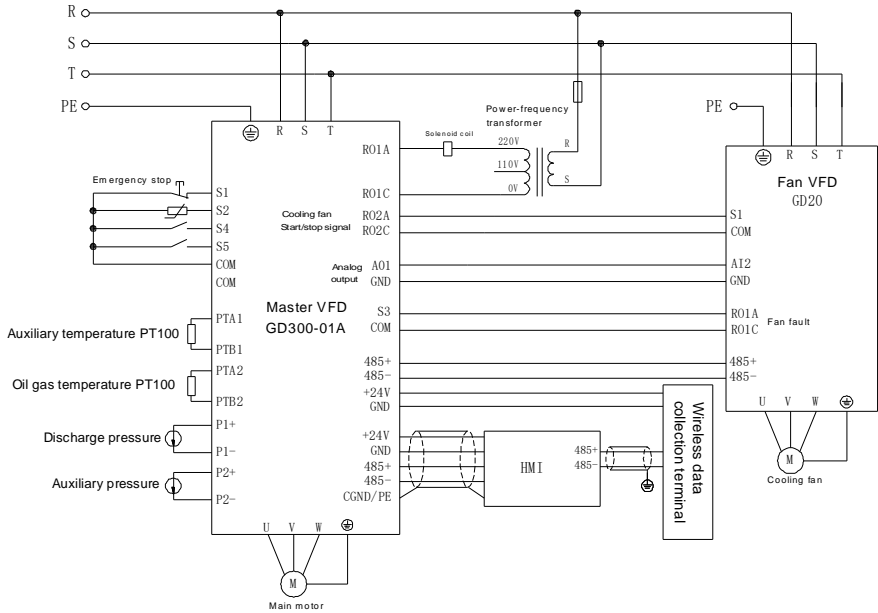

Figure 4-1 Wiring diagram of dual-VFD air compressor system

#### 4.1.2 Commissioning steps for the dual-VFD air compressor

It is recommended to use TC070A touch screen for display and commissioning.

**Note:**

- ✧ If you use a controller from another manufacturer, contact INVT technical support.
- ✧ All the parameters displayed in the interfaces and are subject to actual displayed content.

The commissioning steps are as follows:

1. Perform wiring according to Figure 4-1 and ensure that the VFD for air compressor and the housing of the air compressor are grounded properly.
2. After power up, the following interface is displayed.

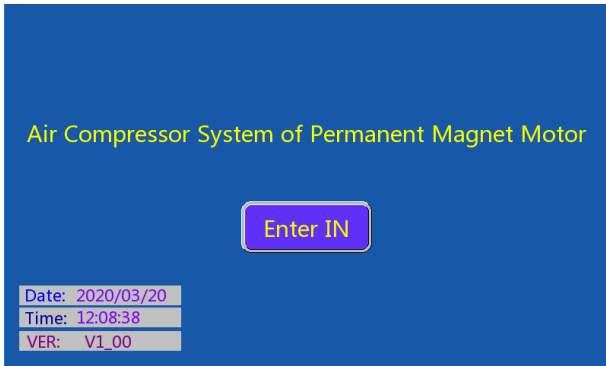

Figure 4-2 Login interface

3. Click **Enter IN** to enter the working environment interface, as shown in Figure 4-3.

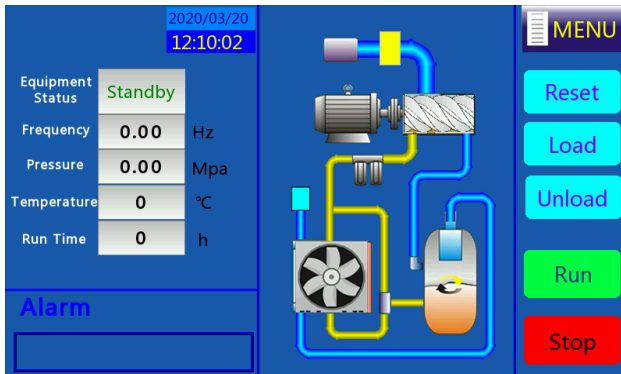

Figure 4-3 Working interface

4. Click **Menu** on the interface. The interface shown in Figure 4-4 is displayed.

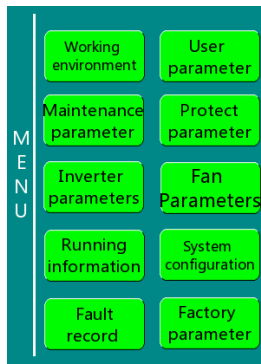

Figure 4-4 Menu interface

5. Click **System config** on the touch screen to enter the system configuration interface, as shown in Figure 4-5.

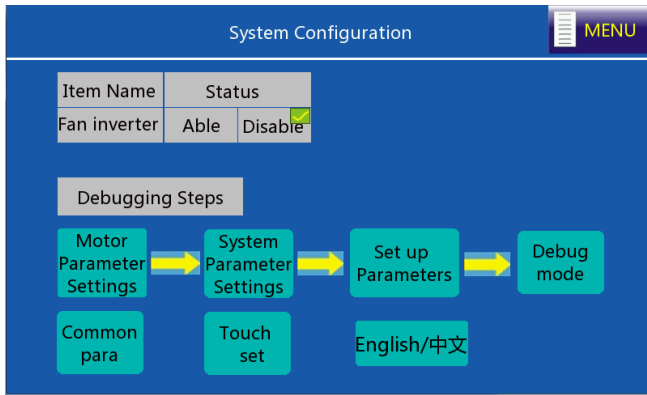
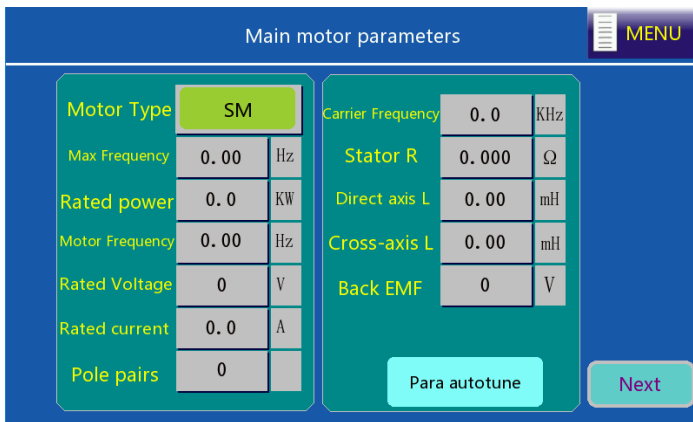

Figure 4-5 System configuration interface

Click **Able** for the fan VFD, and perform commissioning according to the commissioning guide.

Step 1 In the system configuration interface, click **Motor Parameter Settings** to select the motor type.

- ✧ If you select **SM** (synchronous motor), you need to set the max frequency, rated frequency, rated power, rated voltage, rated current, pole pairs, and carrier frequency.
- ✧ If you select **AM** (asynchronous motor), you need to set the max frequency, rated frequency, rated power, rated voltage, rated current, rated rotational speed, and carrier frequency.



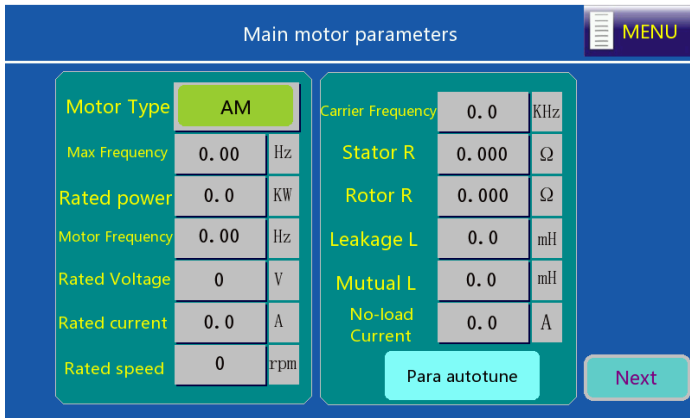

Figure 4-6 Main motor parameter setting interface

Set motor parameters according to the actual motor nameplate parameters, click **Para autotune**, and then click **Next**. On the interface shown, set fan motor parameters (including the max frequency, rated frequency, rated power, rated voltage, rated current, and rated rotational speed).

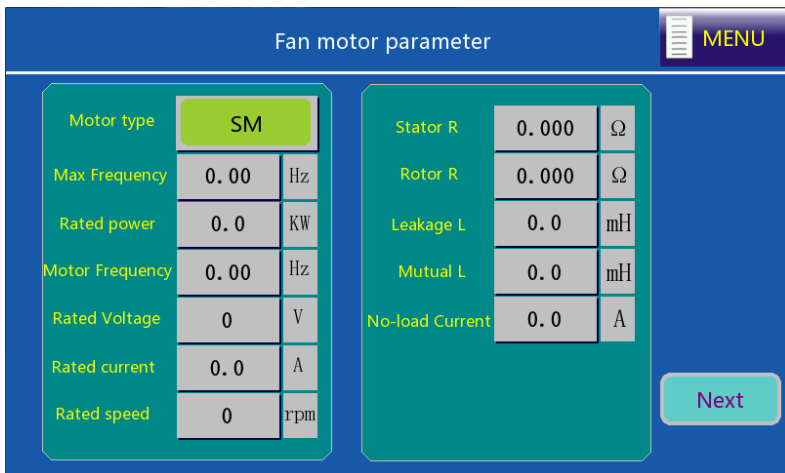

Figure 4-7 Fan motor parameter setting interface

Step 2 On the system configuration interface, click **Set up Parameters**. The system completes the related parameter configuration automatically.

For details about parameter configuration, see the following table. S terminal and RO output terminal functions can be modified according to the system wiring conditions.

Function code	Parameter setting	Description
P00.00	0 or 2	0: SVC mode 0 (applicable to AM, SM)

Function code	Parameter setting	Description
		2: V/F control Select the mode according to the motor type.
P00.01	2	2: Communication
P00.06	7	Set via PID control
P01.15	35.00	Stop frequency: 35Hz
P03.27	1	Display as per the set value
P09.00	10	Pressure setting of dedicated function of air compressor
P09.02	8	Pressure feedback of dedicated function of air compressor
P11.15	0	Speed deviation protection is disabled
P05.01	6	Coast to stop
P05.10	3	Reversal of S1 and S2 terminal polarity
P05.02	46	External fault (motor overtemperature)
P06.02	29	Cooling fan control of main motor
P06.03	28	Solenoid valve control output
P06.04	27	Fan start/stop control
P05.32	2.04	Lower limit value of P1 corresponds to voltage 2.04V

Step 3 Click **Next** to enter **Parameters Configuration** or click **Back** to return to system configuration. On the system configuration interface, click **System Para Config**. S1 functions as emergency-stop switch, select **NO** or **NC** based on the polarity of the emergency-stop switch, as shown in Figure 4-8. When S2 functions as motor overtemperature, select **NC** based on the polarity.

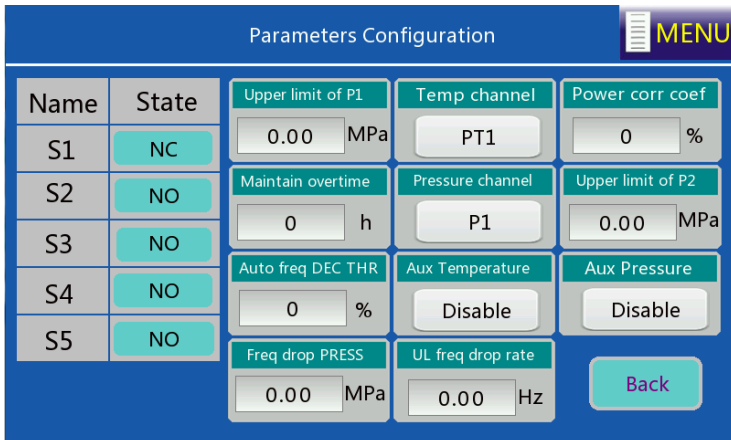

Figure 4-8 System parameter configuration interface

Step 4 On the system configuration interface, click **Debug Mode**. The interface shown in Figure 4-9 is displayed.

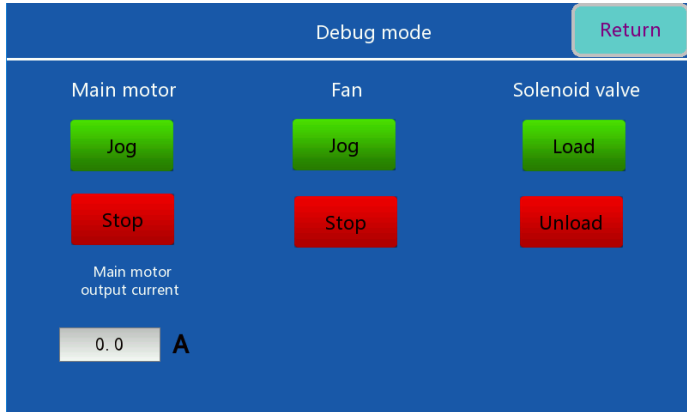

Figure 4-9 Debug mode interface

Click **Jog** for the main motor to determine the motor rotation direction; click **Load** or **Unload** to test the action of solenoid valve. Click **Return** to enter system configuration, then, click **Menu** to return to the menu interface.

**Note:** If the motor rotates reversely, adjust the wiring sequence of the motor cable.

6. Choose **User parameters** in the menu. The interface shown in Figure 4-10 is displayed.

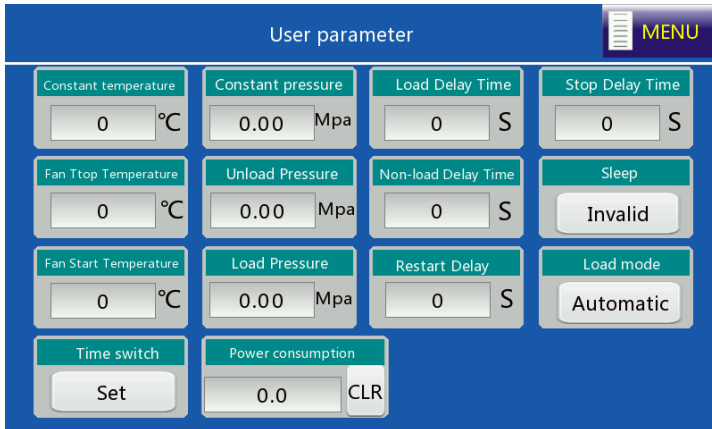

Figure 4-10 User parameter interface

7. Choose **Maintenance parameter** in the menu. The interface shown in Figure 4-11 is displayed.

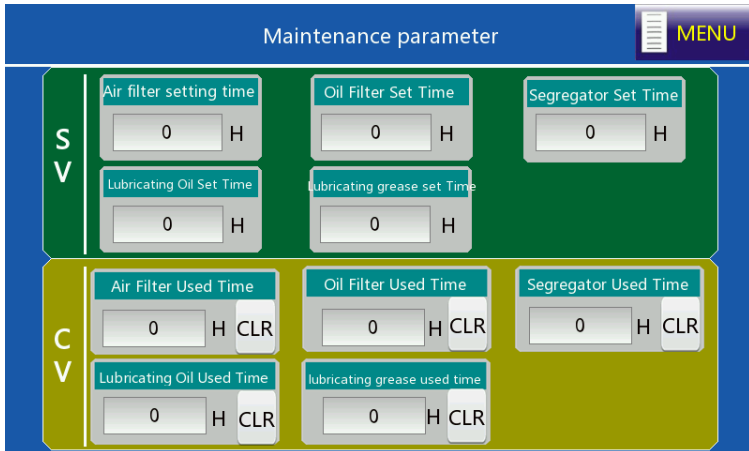

Figure 4-11 Maintenance parameter interface

8. Choose **Protect parameter** in the menu. The interface shown in Figure 4-12 is displayed.

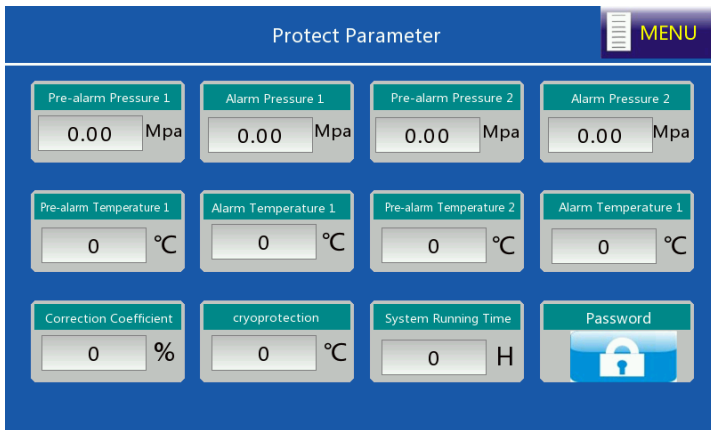

Figure 4-12 Protection parameter interface

9. Choose **Running Info** in the menu. The interface shown in Figure 4-13 is displayed.

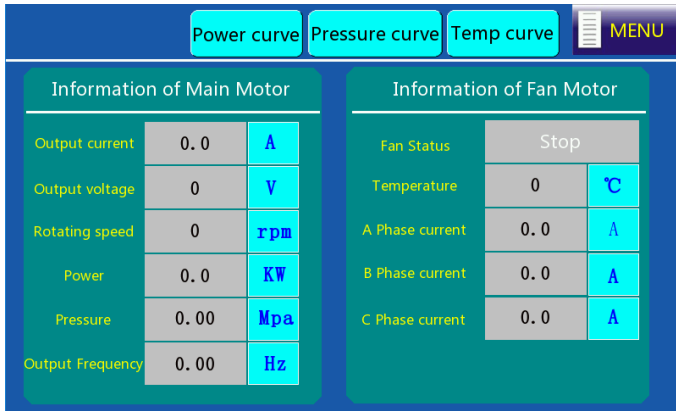

Figure 4-13 Running information interface

10. After adjusting user parameters, factory parameters and maintenance parameters according to the manual, return to **Workspace** interface and click **Start** to run.

## 4.2 Commissioning guidance for single-VFD air compressor

### 4.2.1 Wiring diagram for single-VFD air compressor system

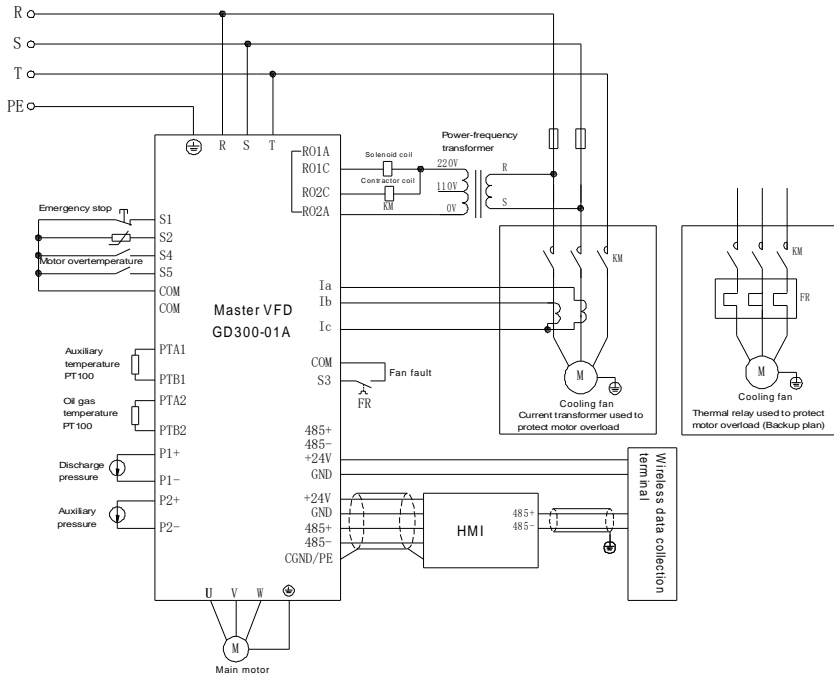
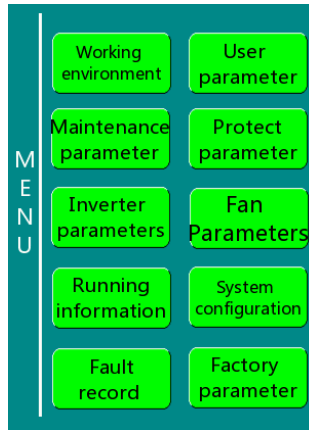

Figure 4-14 Wiring diagram for single-VFD air compressor system

**Note:** Pay attention to the terminals with the same name when installing and wiring the current transformer. For details, see Appendix C "Current transformer of the fan" for precautions.

**4.2.2 Commissioning steps for single-VFD air compressor**

1. Perform similar operations described in section 4.1.2 "Commissioning steps for the dual-VFD air compressor", but you need to turn off the variable-frequency fan on the **System Configuration** interface.



2. Choose **Fan Parameters**. Set the fan rated current according to the fan nameplate.

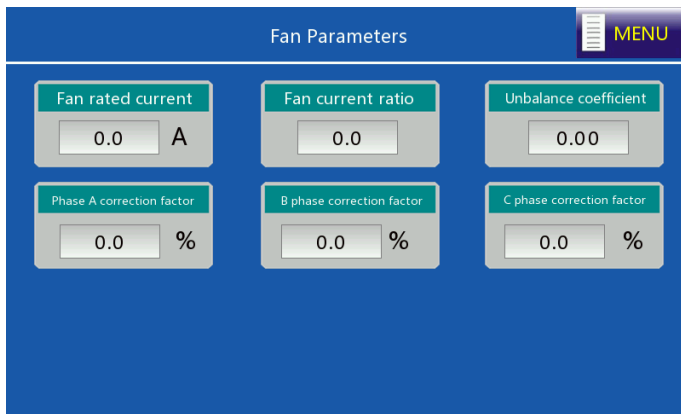

Figure 4-15 Fan parameter interface

3. After adjusting user parameters, factory parameters and maintenance parameters according to the touch screen manual, return to the **Working environment** interface, and click **Start** to run.

### 4.3 Commissioning guidance for dual-VFD + power-frequency fan scheme

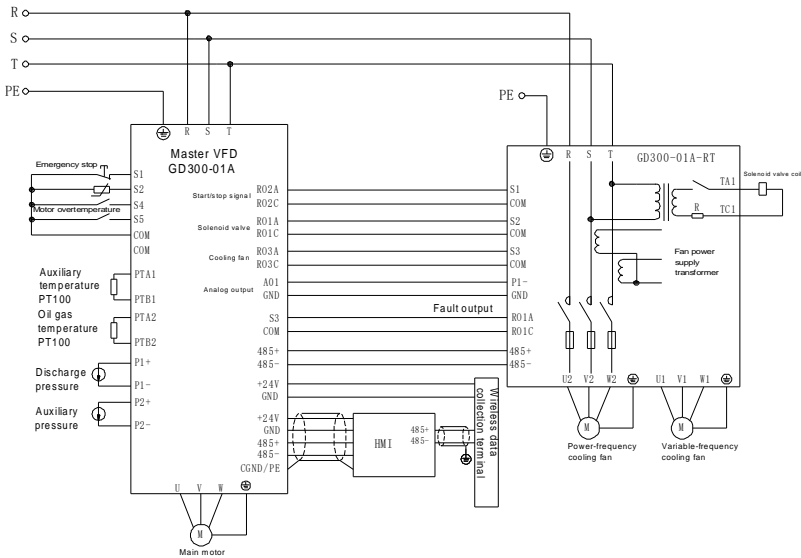

Figure 4-16 Wiring diagram for dual-VFD + power-frequency fan system

Method of application:

Configure the parameters according to section 4.1 "Commissioning instruction for the dual-VFD air compressor", as shown in the following table. You can realize the dual fan system of main motor frequency conversion, in which U1, V1, and W1 terminals of GD300-01A-RT VFD can be used to realize variable-frequency fan output, and U2, V2, W2 terminals can be used to realize power frequency fan output.

GD300-01A-RT parameter configuration table

Function code	Name	Parameter setting	Remarks
P00.00	Speed control mode	2	0: SVC mode 0 (applicable to AM, SM) 1: SVC mode 1 (applicable to AM) 2: V/F control <b>Note:</b> AM: Asynchronous motor; SM: Synchronous motor;
P00.01	Running command channel	1	0: Keypad (LED off) 1: Terminal (LED blinks) 2: Communication (LED on)
P00.06	A frequency command selection	1	1: Set via analog P1-

Function code	Name	Parameter setting	Remarks
P05.01	S1 terminal function selection	1	1: Forward running
P05.02	S2 terminal function selection	49	49: Solenoid valve control signal
P05.03	S3 terminal function selection	50	50: Cooling fan control signal of main motor
P06.02	RO1 output selection	5	5: VFD fault
P14.00	Local communication address	1	Broadcast address: 1, distinguishing the main motor VFD.
P18.43	Fan control mode	1	1: Terminal, the power-frequency fan starts/stops via terminals;

### 4.4 Commissioning guidance for single-VFD integrated machine

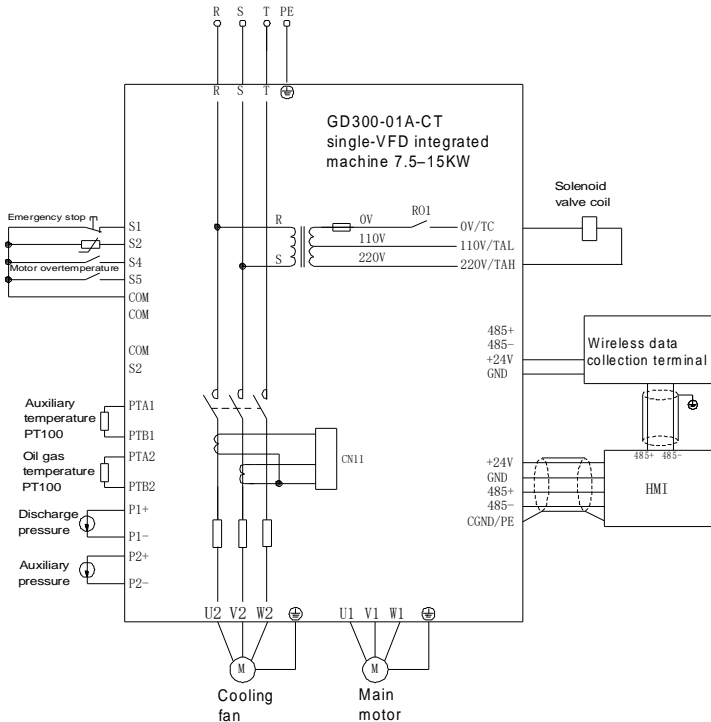

Figure 4-17 Wiring diagram for single-VFD integrated machine system

**Note:**

- ◇ RO1 port of single-VFD integrated machine is connected to solenoid valve coil port by default before delivery. If the touch screen used are made by other manufactures other than INVT, please set RO1 to solenoid valve control (P06.03=28).
- ◇ Refer to section 4.2.2 "Commissioning steps for single-VFD air compressor" to perform commissioning on single-VFD integrated machine.

## Chapter 5 Function code description

### 5.1 Function codes

“○” indicates the parameter value can be modified during stop and running;

“◎” indicates the parameter value cannot be modified when the VFD is running;

“●” indicates the parameter value is the actually detected value which cannot be modified.

(The modification attribute of each parameter has been restricted automatically by the VFD to avoid inadvertent modification)

#### P00 group Basic functions

Function code	Name	Description	Default	Modify
P00.00	Speed control mode	0: SVC mode 0 (applicable to AM, SM) 1: SVC mode 1(applicable to AM) 2: V/F control <b>Note:</b> AM: Asynchronous motor; SM: Synchronous motor; If vector mode is adopted, it is a must to carry out motor parameter autotuning on the VFD first.	0	◎
P00.01	Running command channel	0: Keypad (LED off) 1: Terminal (LED blinks) 2: Communication (LED on)	0	○
P00.02	Communication running command channel	0: Modbus communication 1–3: Reserved	0	○
P00.03	Max. output frequency	P00.04–600.00Hz (400.00Hz)	50.00Hz	◎
P00.04	Upper limit of running frequency	P00.05–P00.03 (max. frequency)	50.00Hz	○
P00.05	Lower limit of running frequency	0.00Hz–P00.04 (upper limit of running frequency)	0.00Hz	○
P00.06	A frequency command selection	<b>Note:</b> A frequency and B frequency cannot use the same frequency reference mode. You can set the frequency source through P00.09. 0: Set via keypad digits 1: Set via analog P1- 2: Reserved 3: Set via analog P2- 4: Reserved	0	○
P00.07	B frequency command selection		2	○

Function code	Name	Description	Default	Modify
		5: Reserved 6: Set via multi-step speed running 7: Set via PID control 8: Set via Modbus communication 9-11: Reserved		
P00.08	Reference object of B frequency command	0: Max. output frequency 1: A frequency command	0	○
P00.09	Combination mode of setting source	0: A 1: B 2: (A+B) 3: (A-B) 4: Max. (A, B) 5: Min. (A, B)	0	○
P00.10	Frequency set through keypad	0.00 Hz-P00.03 (max. frequency)	50.00Hz	○
P00.11	Acceleration time 1	0.0-3600.0s	Depend on model	○
P00.12	Deceleration time 1	0.0-3600.0s	Depend on model	○
P00.13	Running direction	0: Run by default direction 1: Run by reverse direction 2: Reverse running prohibited	2	○
P00.14	Carrier frequency setting	1.0-15.0kHz	Depend on model	○
P00.15	Motor parameter autotuning	0: No operation 1: Rotary autotuning 2: Static autotuning 1 (comprehensive autotuning) 3: Static autotuning 2 (partial autotuning)	0	◎
P00.16	AVR function selection	0: Invalid 1: Valid during the whole time	1	○
P00.17	VFD type	0: G type 1: P type	0	◎
P00.18	Function parameter restoration	0: No operation 1: Restore to default value 2: Clear fault history 3: Start/stop the VFD with one click in communication mode (compatible with the	0	◎

Function code	Name	Description	Default	Modify
		Plot controller) 4: Start/stop the VFD with one click in terminal mode (compatible with the Plot controller) 5–6: Reserved 7: Customer 1 parameter 1 8: Customer 1 parameter 2 9: Customer 2 parameter 10: Customer 3 parameter <b>Note:</b> Though restoring to default values is enabled, the motor parameters in P02 group remain unchanged; P05.38, P05.40, P05.48, P05.50, P18.04, P18.28, P18.29, P18.32, P18.33, P18.38, P21.04, P21.05, and P21.06 also remain unchanged.		

**P01 group Start and stop control**

Function code	Name	Description	Default	Modify
P01.01	Starting frequency of direct startup	0.00–50.00Hz	0.50Hz	☉
P01.08	Stop mode selection	0: Decelerate to stop 1: Coast to stop	0	○
P01.15	Stop speed	0.00–100.00Hz	0.50Hz	☉
P01.16	Stop speed detection mode	0: Detect as per the set speed value (judge the ramps frequency) 1: Detect as per the speed feedback value (valid for vector control only)	1	☉
P01.17	Feedback speed detection time	0.00–100.00 s (valid only when P01.16=1)	0.50s	☉
P01.23	Start delay	0.0–60.0 s	0.0s	○

**P02 group Motor 1 parameters**

Function code	Name	Description	Default	Modify
P02.00	Type of motor 1	0: AM 1: SM	0	☉
P02.01	Rated power of AM 1	0.1–3000.0kW	Depend on model	☉
P02.02	Rated frequency of AM 1	0.01Hz–P00.03 (max. frequency)	50.00Hz	☉

Function code	Name	Description	Default	Modify
P02.03	Rated speed of AM 1	1–36000rpm	Depend on model	☉
P02.04	Rated voltage of AM 1	0–1200V	Depend on model	☉
P02.05	Rated current of AM 1	0.8–6000.0A	Depend on model	☉
P02.06	Stator resistor of AM 1	0.001–65.535Ω	Depend on model	○
P02.07	Rotor resistor of AM 1	0.001–65.535Ω	Depend on model	○
P02.08	Leakage inductance of AM 1	0.1–6553.5mH	Depend on model	○
P02.09	Mutual inductance of AM 1	0.1–6553.5mH	Depend on model	○
P02.10	No-load current of AM 1	0.1–6553.5A	Depend on model	○
P02.11	Saturation coefficient 1 of the iron core of AM 1	0.0–100.0%	80.0%	☉
P02.12	Saturation coefficient 2 of the iron core of AM 1	0.0–100.0%	68.0%	☉
P02.13	Saturation coefficient 3 of the iron core of AM 1	0.0–100.0%	57.0%	☉
P02.14	Saturation coefficient 4 of the iron core of AM 1	0.0–100.0%	40.0%	☉
P02.15	Rated power of SM 1	0.1–3000.0kW	Depend on model	☉
P02.16	Rated frequency of SM 1	0.01Hz–P00.03 (max. frequency)	50.00Hz	☉
P02.17	Pole pairs of SM 1	1–50	2	☉
P02.18	Rated voltage of SM 1	0–1200V	Depend on model	☉
P02.19	Rated current of SM 1	0.8–6000.0A	Depend on model	☉
P02.20	Stator resistor of SM 1	0.001–65.535Ω	Depend on model	○
P02.21	Direct-axis inductance of SM 1	0.01–655.35mH	Depend on model	○

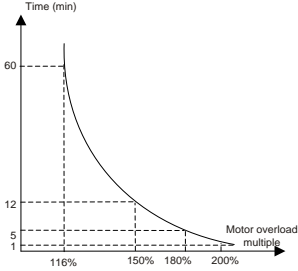
Function code	Name	Description	Default	Modify
P02.22	Quadrature-axis inductance of SM 1	0.01–655.35mH	Depend on model	<input type="radio"/>
P02.23	Counter-emf constant of SM 1	0–10000	350	<input type="radio"/>
P02.26	Overload protection selection of motor 1	0: No protection 1: Normal motor (with low speed compensation) 2: Variable-frequency motor (without low speed compensation)	2	<input checked="" type="radio"/>
P02.27	Overload protection coefficient of motor 1	<p>Motor overload multiple <math>M = I_{out}/(I_n * K)</math>  <math>I_n</math> is rated motor current, <math>I_{out}</math> is VFD output current, <math>K</math> is motor overload protection coefficient.</p> <p>The smaller the <math>K</math> is, the larger the value of <math>M</math> is; the smaller the value of <math>M</math> is, the easier the protection is.</p> <p>When <math>M=116\%</math>, protection is performed after motor overload lasts for 1 hour; when <math>M=150\%</math>, protection is performed after motor overload lasts for 12 minutes; when <math>M=180\%</math>, protection is performed after motor overload lasts for 5 minutes; when <math>M=200\%</math>, protection is performed after motor overload lasts for 60 seconds; and when <math>M \geq 400\%</math>, protection is performed immediately.</p>  <p>Setting range: 20.0%–120.0%</p>	100.0%	<input type="radio"/>
P02.28	Power calibration coefficient of motor 1	0.00–3.00	1.00	<input type="radio"/>
P02.29	Parameter display selection of motor 1	0: Displayed according to the motor type 1: All displayed	0	<input type="radio"/>

**P03 group Vector control**

Function code	Name	Description	Default	Modify																		
P03.00	ASR proportional gain 1	0–200.0	20.0	○																		
P03.01	ASR integral time 1	0.000–10.000s	0.200s	○																		
P03.02	Switching low point frequency	0.00Hz–P03.05	5.00Hz	○																		
P03.03	ASR proportional gain 2	0–200.0	20.0	○																		
P03.04	ASR integral time 2	0.000–10.000s	0.200s	○																		
P03.05	Switching high point frequency	P03.02–P00.03 (max. output frequency)	10.00Hz	○																		
P03.06	ASR output filter	0–8 (corresponds to 0–2 <sup>8</sup> /10ms)	0	○																		
P03.07	Vector control electromotion slip compensation coefficient	50%–200%	100%	○																		
P03.08	Vector control power generation slip compensation coefficient	50%–200%	100%	○																		
P03.09	ACR proportional coefficient P	0–65535 The default value of P03.09 and P03.10 is different within differing power ranges, and the default value will be configured as below after autotuning and setting power range via the touch screen.	Depend on model	○																		
P03.10	ACR integral coefficient I	<table border="1"> <thead> <tr> <th>P03.09 value (reference)</th> <th>P03.10 value (reference)</th> <th>Motor power</th> </tr> </thead> <tbody> <tr> <td>2000</td> <td>1000</td> <td>7.5–22kW</td> </tr> <tr> <td>2500</td> <td>1500</td> <td>30–37kW</td> </tr> <tr> <td>3000</td> <td>1500</td> <td>45–90kW</td> </tr> <tr> <td>3500</td> <td>2000</td> <td>110–132kW</td> </tr> <tr> <td>4000</td> <td>2000</td> <td>160–315kW</td> </tr> </tbody> </table>	P03.09 value (reference)	P03.10 value (reference)	Motor power	2000	1000	7.5–22kW	2500	1500	30–37kW	3000	1500	45–90kW	3500	2000	110–132kW	4000	2000	160–315kW	Depend on model	○
P03.09 value (reference)	P03.10 value (reference)	Motor power																				
2000	1000	7.5–22kW																				
2500	1500	30–37kW																				
3000	1500	45–90kW																				
3500	2000	110–132kW																				
4000	2000	160–315kW																				
P03.20	Keypad setting of the upper limit of electromotive torque	0.0–300.0% (rated motor current)	180.0%	○																		

Function code	Name	Description	Default	Modify
P03.21	Keypad setting of the upper limit of brake torque	0.0–300.0% (rated motor current)	180.0%	<input type="radio"/>
P03.22	Flux-weakening coefficient in constant power area	0.1–2.0	0.3	<input type="radio"/>
P03.23	Min. flux-weakening point in constant power area	10%–100%	20%	<input type="radio"/>
P03.24	Max. voltage limit	0.0–120.0%	100.0%	<input type="radio"/>
P03.25	Pre-excitation time	0.000–10.000s	0.300s	<input type="radio"/>
P03.26	Flux-weakening proportional gain	0–8000	300	<input type="radio"/>
P03.27	Vector control speed display selection	0: Display as per actual value 1: Display as per the set value	0	<input type="radio"/>
P03.28	IF starting current	0–100.0% (rated current of the motor)	60.0%	<input type="radio"/>

**P04 group Space voltage vector control**

Function code	Name	Description	Default	Modify
P04.00	V/F curve setting of motor 1	0: Straight V/F curve 1: Multi-point V/F curve 2: Torque step-down V/F curve (1.3 order) 3: Torque step-down V/F curve (1.7 order) 4: Torque step-down V/F curve (2.0 order) 5: Reserved	0	<input checked="" type="radio"/>
P04.01	Torque elevation of motor 1	0.0%: (automatic) 0.1%–10.0%	0.0%	<input type="radio"/>
P04.02	Torque elevation cut-off of motor 1	0.0%–50.0% (relative to rated frequency of motor 1)	20.0%	<input type="radio"/>
P04.03	V/F frequency point 1 of motor 1	0.00Hz–P04.05	0.00Hz	<input type="radio"/>
P04.04	V/F voltage point 1 of motor 1	0.0%–110.0% (rated voltage of motor 1)	00.0%	<input type="radio"/>
P04.05	V/F frequency point 2 of motor 1	P04.03–P04.07	00.00Hz	<input type="radio"/>
P04.06	V/F voltage point 2 of motor 1	0.0%–110.0% (rated voltage of motor 1)	00.0%	<input type="radio"/>
P04.07	V/F frequency point 3	P04.05–P02.02 (rated frequency of motor 1)	00.00Hz	<input type="radio"/>

Function code	Name	Description	Default	Modify
	of motor 1	/P04.05–P02.16 (rated frequency of motor 1)		
P04.08	V/F voltage point 3 of motor 1	0.0%–110.0% (rated voltage of motor 1)	00.0%	○
P04.09	V/F slip compensation gain of motor 1	0.0–200.0%	100.0%	○
P04.10	Low-frequency vibration control factor of motor 1	0–100	10	○
P04.11	High-frequency vibration control factor of motor 1	0–100	10	○
P04.12	Vibration control threshold of motor 1	0.00Hz–P00.03 (max. frequency)	30.00Hz	○
P04.26	Energy conservation running selection	0: No action 1: Automatic energy-saving running	0	◎
P04.33	Flux-weakening coefficient in constant power area	1.00–1.30	1.00	○
P04.34	Reactive closed-loop proportional coefficient	0–3000 When the SM V/F control mode is enabled, the function code is used to set the proportional coefficient of the reactive current closed-loop control.	100	○
P04.35	Reactive closed-loop integral coefficient	0–3000 When the SM V/F control mode is enabled, the function code is used to set the integral coefficient of the reactive current closed-loop control.	20	○

**P05 group Input terminals**

Function code	Name	Description	Default	Modify
P05.00	Reserved	Reserved	0	◎
P05.01	S1 terminal function selection	0: No function 1: Forward running	0	◎
P05.02	S2 terminal function selection	2: Reverse running 3: Three-line running control	0	◎
P05.03	S3 terminal function selection	4: Forward jogging 5: Reverse jogging	0	◎

Function code	Name	Description	Default	Modify																				
P05.04	S4 terminal function selection	6: Coast to stop 7: Fault reset	0	⊙																				
P05.05	S5 terminal function selection	8: Running pause 9: External fault input	0	⊙																				
P05.06	Reserved	10–24: Reserved 25: PID control pause 26–39: Reserved 40: Zero out power consumption 41: Maintain power consumption 42: Air filter blockage signal 43: Oil filter blockage signal 44: Separator blockage signal 45: Precision splitter blockage signal 46: External fault 1 (motor overtemperature) 47: External fault 2 48: Reserved 49: Solenoid valve control signal 50: Cooling fan control signal of main motor 51–63: Reserved		⊙																				
P05.10	Input terminal polarity selection	<p>This function code is used to set the input terminal polarity.</p> <p>When the bit is set to 0, input terminal polarity is positive;</p> <p>When the bit is set to 1, input terminal polarity is negative.</p> <table border="1" style="margin-left: auto; margin-right: auto;"> <tr> <td></td> <td>BIT8</td> <td>BIT7</td> <td>BIT6</td> <td>BIT5</td> </tr> <tr> <td></td> <td colspan="4" style="text-align: center;">Reserved</td> </tr> <tr> <td></td> <td>BIT4</td> <td>BIT3</td> <td>BIT2</td> <td>BIT1</td> </tr> <tr> <td></td> <td>S5</td> <td>S4</td> <td>S3</td> <td>S2</td> </tr> </table> <p>Setting range: 0x000–0x1FF</p>		BIT8	BIT7	BIT6	BIT5		Reserved					BIT4	BIT3	BIT2	BIT1		S5	S4	S3	S2	0x000	○
	BIT8	BIT7	BIT6	BIT5																				
	Reserved																							
	BIT4	BIT3	BIT2	BIT1																				
	S5	S4	S3	S2																				
P05.11	Digital filter time	0.000–1.000s	0.200s	○																				
P05.14	S1 terminal switch-on delay	0.000–50.000s	0.000s	○																				
P05.15	S1 terminal switch-off delay	0.000–50.000s	0.000s	○																				
P05.16	S2 terminal switch-on delay	0.000–50.000s	0.000s	○																				

Function code	Name	Description	Default	Modify
P05.17	S2 terminal switch-off delay	0.000–50.000s	0.000s	<input type="radio"/>
P05.18	S3 terminal switch-on delay	0.000–50.000s	0.000s	<input type="radio"/>
P05.19	S3 terminal switch-off delay	0.000–50.000s	0.000s	<input type="radio"/>
P05.20	S4 terminal switch-on delay	0.000–50.000s	0.000s	<input type="radio"/>
P05.21	S4 terminal switch-off delay	0.000–50.000s	0.000s	<input type="radio"/>
P05.22	S5 terminal switch-on delay	0.000–50.000s	0.000s	<input type="radio"/>
P05.23	S5 terminal switch-off delay	0.000–50.000s	0.000s	<input type="radio"/>
P05.32	Lower limit value of P1	The corresponding percentage is obtained based on the relationship between the upper and lower limits and their corresponding settings, shown in the following figure. Present pressure = corresponding percentage × pressure sensor P1 upper limit	2.00V	<input type="radio"/>
P05.33	Corresponding setting of lower limit of P1		0.0%	<input type="radio"/>
P05.34	Upper limit value of P1		10.00V	<input type="radio"/>
P05.35	Corresponding setting of upper limit of P1	<p>Setting range of P05.32: 0.00V - P05.34                      Setting range of P05.33: -100.0% - 100.0%                      Setting range of P05.34: P05.32 - 10.00V                      Setting range of P05.35: -100.0% - 100.0%</p>	100.0%	<input type="radio"/>
P05.36	P1 input filter time	0.000s–10.000s	0.200s	<input type="radio"/>
P05.37	PT1 lower limit value	Corresponding setting of the upper and lower limits are set as a percentage that temperature calibration point accounts for total range, and analog percentage	0.00V	<input type="radio"/>
P05.38	Corresponding setting of lower limit of PT1		-12.5%	<input type="radio"/>
P05.39	PT1 upper limit value		10.00V	<input type="radio"/>

Function code	Name	Description	Default	Modify
P05.40	Corresponding setting of upper limit of PT1	<p>corresponding to input voltage can be obtained by the linear relationship between the upper and lower limits and their corresponding settings.</p> <p>Present temperature = corresponding percentage × 160℃</p> <p><b>Note:</b> Though restoring to default values is enabled, P05.38, P05.40, P05.48, and P05.50 also remain unchanged.</p> <p>Setting range of P05.37: 0.00V–P05.39                      Setting range of P05.38: -100.0%–100.0%                      Setting range of P05.39: P05.37–10.00V                      Setting range of P05.40: -100.0%–100.0%</p>	75.0%	○
P05.41	PT1 input filter time	0.000s–10.000s	0.300s	○
P05.42	P2 lower limit value	0.00V–P05.44	2.00V	○
P05.43	Corresponding setting of lower limit of P2	-100.0%–100.0%	0.0%	○
P05.44	P2 upper limit value	P05.42–10.00V	10.00V	○
P05.45	Corresponding setting of upper limit of P2	-100.0%–100.0%	100.0%	○
P05.46	P2 input filter time	0.000s–10.000s	0.200s	○
P05.47	PT2 lower limit value	0.00V–P05.49	0.00V	○
P05.48	Corresponding setting of lower limit of PT2	-100.0%–100.0%	-12.5%	○
P05.49	PT2 upper limit value	P05.47–10.00V	10.00V	○
P05.50	Corresponding setting of upper limit of PT2	-100.0%–100.0%	75.0%	○
P05.51	PT2 input filter time	0.000s–10.000s	0.300s	○

**P06 group Output terminals**

Function code	Name	Description	Default	Modify				
P06.01	Reserved	0: Invalid	0	<input type="radio"/>				
P06.02	RO3 output selection	1: In running	0	<input type="radio"/>				
P06.03	RO1 output selection	2: In forward running	0	<input type="radio"/>				
P06.04	RO2 output selection	3: In reverse running	0	<input type="radio"/>				
		4: In jogging						
		5: VFD fault						
		6–11: Reserved						
		12: Ready to run						
		13: In pre-exciting						
		14–19: Reserved						
		20: External fault is valid						
		21–22: Reserved						
		23: Modbus communication virtual terminal output						
		24–25: Reserved						
		26: Function only for oil pump (blower)						
		27: Fan start/stop control						
28: Solenoid valve control output								
29: Cooling fan control of main motor								
30: Reserved								
P06.05	Output terminal polarity selection	This function code is used to set the output terminal polarity. When the bit is set to 0, output terminal polarity is positive; When the bit is set to 1, output terminal polarity is negative.	0	<input type="radio"/>				
		<table border="1" style="margin-left: auto; margin-right: auto;"> <tr> <td>BIT3</td> <td>BIT2</td> <td>BIT1</td> <td>BIT0</td> </tr> <tr> <td>RO2</td> <td>RO1</td> <td>RO3</td> <td>Reserved</td> </tr> </table>			BIT3	BIT2	BIT1	BIT0
BIT3	BIT2	BIT1	BIT0					
RO2	RO1	RO3	Reserved					
		Setting range: 0–0xF						
P06.08	RO3 switch-on delay	0.000–50.000s	0.000s	<input type="radio"/>				
P06.09	RO3 switch-off delay	0.000–50.000s	0.000s	<input type="radio"/>				
P06.10	RO1 switch-on delay	0.000–50.000s	0.000s	<input type="radio"/>				
P06.11	RO1 switch-off delay	0.000–50.000s	0.000s	<input type="radio"/>				
P06.12	RO2 switch-on delay	0.000–50.000s	0.000s	<input type="radio"/>				
P06.13	RO2 switch-off delay	0.000–50.000s	0.000s	<input type="radio"/>				
P06.14	AO1 output selection	0: Running frequency	24	<input type="radio"/>				
		1: Set frequency						

Function code	Name	Description	Default	Modify
		2: Ramps reference frequency 3: Running speed (relative to two times the motor synchronous rotation speed) 4: Output current (relative to two times the rated current of the VFD) 5: Output current (relative to two times the current of the motor) 6: Output voltage (relative to 1.5 times the rated current of the VFD) 7: Output power (relative to two times the motor rated power) 8: Reserved 9: Output torque (relative to two times the rated torque of the motor) 10–13: Reserved 14: Value 1 set through Modbus communication 15: Value 2 set through Modbus communication 16–21: Reserved 22: Torque current (relative to three times the rated current of the motor) 23: Ramp frequency reference (with sign) 24: Temperature PID output 25–30: Reserved		
P06.17	Lower limit of AO1 output	-100.0%–P06.19	0.0%	<input type="radio"/>
P06.18	Corresponding AO1 output of lower limit	0.00V–10.00V	0.00V	<input type="radio"/>
P06.19	Upper limit of AO1 output	P06.17–100.0%	100.0%	<input type="radio"/>
P06.20	Corresponding AO1 output of upper limit	0.00V–10.00V	10.00V	<input type="radio"/>
P06.21	AO1 output filter time	0.000s–10.000s	0.000s	<input type="radio"/>

**P07 group HMI**

Function code	Name	Description	Default	Modify
P07.00	User password	0-65535	0	○
P07.01	Function parameter copy	<p>0: No operation            1: Uploading function parameters from the machine to keypad            2: Downloading function parameters (including the motor parameters) from the keypad to machine            3: Downloading function parameters (excluding motor parameters of the P02 and P12 groups) from the keypad to machine            4: Downloading function parameters (only motor parameters of the P02 and P12 groups) from the keypad to machine</p> <p><b>Note:</b>            After the parameter is set to 1, 2, 3 or 4, and the operation is executed, the parameter is automatically restored to 0.</p>	0	◎
P07.02	Function selection of the <b>QUICK/JOG</b> key	<p>0: No function            1: Jogging            2: Switching display status through the shifting key            3: Forward/reverse running switching            4: Clearing the setting of <b>UP/DOWN</b>            5: Coasting to stop            6: Switching running-command giving methods in sequence            7: Quick debugging mode (non factory parameter debugging)</p>	1	◎
P07.11	Temperature of rectifier bridge module	0-100.0°C		●
P07.12	Temperature of inverter module	0-100.0°C		●
P07.13	Software version of control board	1.00-655.35		●
P07.14	Accumulated running time	0-65535h		●

Function code	Name	Description	Default	Modify
P07.15	High bit of power consumption of the VFD	0–65535 kWh (*1000)		●
P07.16	Low bit of power consumption of the VFD	0.0–999.9 kWh		●
P07.17	VFD model	0: G type 1: P type		●
P07.18	Rated VFD power	0.4–3000.0kW		●
P07.19	Rated VFD voltage	50–1200V		●
P07.20	Rated VFD current	0.1–6000.0A		●
P07.21	Factory barcode 1	0x0000–0xFFFF		●
P07.22	Factory barcode 2	0x0000–0xFFFF		●
P07.23	Factory barcode 3	0x0000–0xFFFF		●
P07.24	Factory barcode 4	0x0000–0xFFFF		●
P07.25	Factory barcode 5	0x0000–0xFFFF		●
P07.26	Factory barcode 6	0x0000–0xFFFF		●
P07.27	Type of present fault	0: No fault		●
P07.28	Type of the last fault	1: Inverter unit U phase protection (OUT1)		●
P07.29	Type of the last but one fault	2: Inverter unit V phase protection (OUT2) 3: Inverter unit W phase protection (OUT3)		●
P07.30	Type of the last but two fault	4: Overcurrent at acceleration (OC1) 5: Overcurrent at deceleration (OC2)		●
P07.31	Type of the last but three fault	6: Overcurrent at constant speed (OC3) 7: Overvoltage at acceleration (OV1)		●
P07.32	Type of the last but four fault	8: Overvoltage at deceleration (OV2) 9: Overvoltage at constant speed (OV3) 10: Bus undervoltage fault (UV) 11: Motor overload (OL1) 12: VFD overload (OL2) 13: Phase loss on input side (SPI) 14: Phase loss on output side (SPO) 15: Rectifier module overheat (OH1) 16: Inverter module overheat (OH2) 17: External fault (EF) 18: 485 communication fault (CE) 19: Current detection fault (ItE) 20: Motor autotuning fault (tE)		●





Function code	Name	Description	Default	Modify
		21: EEPROM operation fault (EEP) 22: PID feedback offline fault (PIDE) 23: Reserved 24: Running time reached (END) 25: Electronic overload (OL3) 26: Panel communication error (PCE) 27: Parameter upload error (UPE) 28: Parameter download error (DNE) 29–31: Reserved 32: To-ground short circuit fault 1 (ETH1) 33: To-ground short circuit fault 2 (ETH2) 34: Speed deviation fault (dEu) 35: Maladjustment fault (STO) 36: Underload fault (LL) 37: Reserved 38: Phase sequence fault (PSF) 39: 3PH current imbalance of the fan (SPOF) 40: Fan overload (OLF) 41: Encoder offline fault (ENC1O) 42: Encoder reverse fault (ENC1D) 43: Encoder Z pulse offline fault (ENC1Z) 44: Auxiliary pressure too low fault (L-AUP) 45: Handshake failure fault (HAnd)		
P07.33	Running frequency at present fault		0.00	●
P07.34	Ramp reference frequency at present fault		0.00	●
P07.35	Output voltage at present fault		0	●
P07.36	Output current at present fault		0.0	●
P07.37	Bus voltage at present fault		0.0	●
P07.38	Max. temperature at present fault		0.0	●
P07.39	Input terminal status at present fault		0	●

Function code	Name	Description	Default	Modify
P07.40	Output terminal status at present fault		0	●
P07.41	Running frequency at last fault		0.00	●
P07.42	Ramp reference frequency at last fault		0.00	●
P07.43	Output voltage at last fault		0	●
P07.44	Output current at last fault		0.0	●
P07.45	Bus voltage at last fault		0.0	●
P07.46	Max. temperature at last fault		0.0	●
P07.47	Input terminal status at last fault		0.0	●
P07.48	Output terminal status at last fault		0	●
P07.49	Running frequency at last fault		0	●
P07.50	Ramp reference frequency at 2nd-last fault		0.00	●
P07.51	Output voltage at 2nd-last fault		0	●
P07.52	Output current at 2nd-last fault		0	●
P07.53	Bus voltage at 2nd-last fault		0.0	●
P07.54	Max. temperature at 2nd-last fault		0.0	●
P07.55	Input terminal status at 2nd-last fault		0	●
P07.56	Output terminal status at 2nd-last fault		0	●

**P08 group Enhanced functions**

Function code	Name	Description	Default	Modify
P08.15	Bus voltage pre-protection function	0–0x11Ones: Bus protection function Tens: Low-frequency current protection function	0x10	<input type="radio"/>
P08.16	Low-voltage protection threshold	0.0V–2000.0V	300.0V	<input type="radio"/>
P08.17	Overvoltage pre-protection threshold	0.0V–2000.0V	780.0V	<input type="radio"/>
P08.18	Automatic restart delay	0.0–6000.0s	60.0s	<input type="radio"/>
P08.19	Low-voltage frequency limit running time	0.0–6000.0s	60.0s	<input type="radio"/>
P08.20	High-frequency current loop proportional gain	0–20000	1000	<input type="radio"/>
P08.21	High-frequency current loop integral time	0–20000	1000	<input type="radio"/>
P08.23	High-frequency current loop switching frequency	0.0–100.0% (max. output frequency P00.03)	100.0%	<input type="radio"/>
P08.24	Fan control enable selection	0–1 0: Enable fan control 1: Disable fan control <b>Note:</b> Applicable to 7.5–15kW single-VFD integrated machine only, used to control the start/stop of a power-frequency fan.	0	<input type="radio"/>
P08.25	Keypad lock enable	0: Do not lock keypad 1: Allow to lock keypad Lock: Press PRG key+DATA key simultaneously Unlock: Keep DATA key pressed down and then click V key by three times.	0	<input type="radio"/>
P08.26	Maintenance timing mode	0: No timing during sleep 1: Timing during sleep	0	<input type="radio"/>
P08.27	SM optimal mode selection	0: Disable It is applicable to the surface-mounted synchronous motors. P02.21 (Direct-axis inductance of SM 1) and P02.22 (Quadrature-axis inductance of SM 1) are	0	<input type="radio"/>

Function code	Name	Description	Default	Modify
		used in the calculation. 1: Enable It is applicable to the embedded/ surface-mounted synchronous motors. P02.21 (Direct-axis inductance of SM 1) is used in the calculation. <b>Note:</b> You can disable or enable the optimization mode according to the motor at the scene.		
P08.28	Auto fault reset count	During the automatic reset period, the fault will not be reported externally, only the keypad TRIP indicator blinks, and P17.39 shows the warning code. The automatic fault reset function is enabled for these faults, such as OU1, OU2, Out3, OL1, OL2, OH1, OH2, EF, CE, ItE, tE, EEP, END, PCE, UPE, DNE, ETH1, ETH2, PSF, etc. Fault codes will be reported immediately when these types of faults occur. Setting range of P08.28: 0–10 Setting range of P08.29: 0.1–3600.0s	5	<input type="radio"/>
P08.29	Auto fault reset interval setting	During the automatic reset period, the fault will not be reported externally, only the keypad TRIP indicator blinks, and P17.39 shows the warning code. The automatic fault reset function is enabled for these faults, such as OU1, OU2, Out3, OL1, OL2, OH1, OH2, EF, CE, ItE, tE, EEP, END, PCE, UPE, DNE, ETH1, ETH2, PSF, etc. Fault codes will be reported immediately when these types of faults occur. Setting range of P08.28: 0–10 Setting range of P08.29: 0.1–3600.0s	5.0	<input type="radio"/>
P08.30	Frequency decrease ratio in drop control	0.00–50.00Hz	0.00Hz	<input type="radio"/>
P08.32	FDT1 electrical level detection value	0.00–P00.03 (max. output frequency)	50.00Hz	<input type="radio"/>
P08.33	FDT1 lagging detection value	-100.0–100.0% (FDT1 electrical level)	5.0%	<input type="radio"/>
P08.34	FDT2 electrical level detection value	0.00–P00.03 (max. output frequency)	50.00Hz	<input type="radio"/>
P08.35	FDT2 lagging detection value	-100.0–100.0% (FDT2 electrical level)	5.0%	<input type="radio"/>
P08.36	Detection value for frequency being reached	0.0–P00.03 (max. output frequency)	0.00Hz	<input type="radio"/>
P08.39	Cooling fan running mode	0: Common running mode: Do not run during sleep. 1: The fan keeps running after being powered on 2: Temperature control: The fan turns on when	0	<input type="radio"/>

Function code	Name	Description	Default	Modify
		IGBT temperature is higher than 50℃ and turns off when it is lower than 45℃.		
P08.40	PWM selection	0x00–0x21 LED ones: PWM mode selection 0: PWM mode 1, 3PH modulation and 2PH modulation 1: PWM mode 2, 3PH modulation LED tens: PWM low-speed carrier limit 0: Low-speed carrier limit mode 1 1: Low-speed carrier limit mode 2 2: No limit LED hundreds: Reserved	01	⊙
P08.41	Overmodulation selection	0x00–0x11 LED ones: 0: Disable overmodulation 1: Enable overmodulation LED tens: 0: Mild overmodulation 1: Deepened overmodulation	01	⊙
P08.42	Keypad data control setting	0x000–0x1223 LED ones: Frequency enabling selection 0: Both  key and digital potentiometer adjustments are valid 1: Only  keys adjustment is valid 2: Only digital potentiometer adjustment is valid 3: Neither  key nor digital potentiometer adjustment are valid LED tens: Frequency control selection 0: Valid only when P00.06 =0 1: Valid for all frequency setting methods 2: Invalid for multi-step speed running when multi-step speed running has the priority LED hundreds: Action selection for stop 0: Setting is valid. 1: Valid during running, cleared after stop 2: Valid during running, cleared after a stop command is received LED thousands:  keys and digital	0x000	○

Function code	Name	Description	Default	Modify
		potentiometer integral function 0: The integral function is valid 1: The integral function is invalid		
P08.43	Integral time of digital potentiometer	0.01–10.00s	0.10s	○
P08.44	UP/DOWN terminal control setup	0x00–0x221 LED ones: Frequency enabling selection 0: UP/DOWN terminal setup is valid 1: UP/DOWN terminal setup is invalid LED tens: Frequency control selection 0: Valid only when P00.06 =0 1: All frequency modes are valid 2: Invalid for multi-step speed when multi-step speed takes priority LED hundreds: Action selection during stop 0: Setting is valid. 1: Valid during running, cleared after stop 2: Valid during running, cleared after a stop command is received	0x000	○
P08.45	UP terminal frequency incremental change rate	0.01–50.00Hz/s	0.50Hz/s	○
P08.46	DOWN terminal frequency decremental change rate	0.01–50.00Hz/s	0.50Hz/s	○
P08.47	Action selection for frequency setup during power down	0x000–0x111 LED ones: Action selection at power-off during frequency adjusting through digitals. 0: Save the setting at power-off. 1: Clear the setting at power-off. LED tens: Action selection at power-off during frequency adjusting through Modbus communication 0: Save the setting at power-off. 1: Clear the setting at power-off. LED hundreds: Action selection at power-off during frequency adjusting through other communication 0: Save the setting at power-off.	0x000	○

Function code	Name	Description	Default	Modify
		1: Clear the setting at power-off.		
P08.48	High bit of initial value of power consumption	0–59999°(k)	0°	<input type="radio"/>
P08.49	Low bit of initial value of power consumption	0.0–999.9°	0.0°	<input type="radio"/>
P08.50	Flux braking coefficient	0: Disable 100–150: A larger coefficient indicates a stronger brake intensity.	0	<input type="radio"/>
P08.51	VFD input power factor	0.00–1.00	0.56	<input type="radio"/>

**P09 group PID control**

Function code	Name	Description	Default	Modify
P09.00	PID reference source	0: Keypad digits (P09.01) 1: Analog P1- 2: Reserved 3: Analog P2- 4: Reserved 5: Multi-step 6: Modbus communication 7–9: Reserved 10: Pressure setting of dedicated function of air compressor	0	<input type="radio"/>
P09.01	PID reference preset through keypad	-100.0%–100.0%	0.0%	<input type="radio"/>
P09.02	PID feedback source	0: Analog P1- 1: Reserved 2: Analog P2- 3: Reserved 4: Modbus communication 5–7: Reserved 8: Pressure feedback of dedicated function of air compressor	0	<input type="radio"/>
P09.03	PID output characteristics selection	0: PID output characteristic is positive: the feedback signal is larger than PID reference, which requires the VFD output frequency to decrease to balance PID, e.g. tension PID control of winding. 1: PID output characteristic is negative:	0	<input type="radio"/>

Function code	Name	Description	Default	Modify
		feedback signal is larger than PID reference, which requires the VFD output frequency to increase to balance PID, e.g. tension PID control of unwinding.		
P09.04	Proportional gain (Kp)	It determines the regulation intensity of the whole PID regulator, the larger the P is, the stronger the regulation intensity is. if this parameter is 100, it means the regulation amplitude made on output frequency command by the proportional regulator (ignoring integral and differential actions) is the max. frequency (P00.03) when the deviation between PID feedback quantity and reference quantity is 100%. Setting range: 0.00–100.00	10.00	○
P09.05	Integral time (Ti)	It determines the speed of integral regulation made on the deviation between PID feedback quantity and reference quantity by PID regulator. When the deviation between PID feedback quantity and reference quantity is 100%, the regulation quantity (ignoring proportional and differential actions) of integral regulator can reach max. output frequency (P00.03) through continuous regulation in the time set by P09.05. The shorter the integral time, the stronger the regulation intensity. Setting range: 0.00–10.00s	2.00s	○
P09.06	Differential time (Td)	It determines the intensity of variation regulation made on the deviation between PID feedback quantity and reference quantity by PID regulator. If the feedback quantity changes by 100% during the time set by P09.06, the regulation quantity of differential regulator (ignoring proportional and integral actions) is the max. output frequency (P00.03). The longer the differential time, the stronger the regulation intensity.	1.00s	○

Function code	Name	Description	Default	Modify
		Setting range: 0.00–10.00s		
P09.07	Sampling cycle (T)	It means the sampling cycle of feedback quantity. The regulator calculates once during each sampling cycle. The longer the sampling cycle, the slower the response speed. Setting range: 0.001–10.000s	0.100s	<input type="radio"/>
P09.08	Final limit of PID control deviation	It means the max. allowed deviation quantity of the PID system feedback value relative to closed-loop reference value. Within the deviation limit, PID regulator stops regulating, this parameter can be used to regulate the precision and stability of PID system. Setting range: 0.0–100.0%	0.1%	<input type="radio"/>
P09.09	Upper limit value of PID output	P09.10–100.0% (max. frequency)	100.0%	<input type="radio"/>
P09.10	Lower limit value of PID output	-100.0%–P09.09 (max. frequency)	0.0%	<input type="radio"/>
P09.11	Feedback offline detection value	0.0–100.0%	0.0%	<input type="radio"/>
P09.12	Feedback offline detection time	0.0–3600.0s	1.0s	<input type="radio"/>
P09.13	PID regulation selection	0x00–0x11 LED ones: 0: Continue integral regulation when the frequency reaches upper/lower limit 1: Stop integral regulation when the frequency reaches upper/lower limit LED tens: 0: The same with the set direction 1: Contrary to the set direction	0x01	<input type="radio"/>
P09.14	Differential filter times	0–60	2	<input type="radio"/>

**P11 group Protection parameters**

Function code	Name	Description	Default	Modify
P11.00	Phase loss protection	0x0000–0x1111 LED ones: 0: Disable input phase loss software protection	0x0110	<input type="radio"/>

Function code	Name	Description	Default	Modify
		1: Enable input phase loss software protection <b>Note:</b> LED ones place detects input phase loss by phase sequence detection circuit. LED tens: 0: Disable output phase loss protection 1: Enable output phase loss protection LED hundreds: 0: Disable input phase loss hardware protection 1: Enable input phase loss hardware protection <b>Note:</b> LED hundreds place detects input phase loss by hardware detection circuit. LED thousands: 0: Disable phase sequence protection 1: Enable phase sequence protection		
P11.01	Frequency drop at transient power dip	0: Disable 1: Enable	0	<input type="radio"/>
P11.02	Frequency drop rate at transient power dip	0.00Hz~P00.03/s (max. frequency)	10.00Hz/s	<input type="radio"/>
P11.03	Overvoltage stall protection	0: Disable 1: Enable	1	<input type="radio"/>
P11.04	Overvoltage stall protection voltage	120~150% (standard bus voltage) (380V)	140%	<input type="radio"/>
P11.05	Current limit selection	0x00~0x11 Ones: Current-limit action selection 0: Current-limit action is invalid 1: Current-limit action is always valid Tens: Hardware current-limit overload alarm selection 0: Hardware current-limit overload alarm is valid 1: Hardware current-limit overload alarm is invalid	01	<input checked="" type="radio"/>
P11.06	Automatic current-limit level	50.0~200.0%	160.0%	<input checked="" type="radio"/>
P11.07	Frequency drop rate at current limit	0.00~50.00Hz/s	10.00Hz/s	<input checked="" type="radio"/>

Function code	Name	Description	Default	Modify
P11.08	Pre-alarm selection for VFD/motor overload/underload	0x000–0x131 LED ones: 0: Motor overload/underload pre-alarm, relative to the motor rated current, 1: VFD overload/underload pre-alarm, relative to the VFD rated current LED tens: 0: The VFD keeps running after reporting an overload/underload alarm. 1: The VFD keeps running after reporting an underload alarm, but it stops running after reporting an overload alarm. 2: The VFD keeps running after reporting an overload alarm, but it stops running after reporting an underload alarm. 3: The VFD stops running after reporting an overload/underload alarm. LED hundreds: 0: Always detect 1: Detect only in constant speed running	0x000	○
P11.13	Fault output terminal action during fault	0x00–0x11 LED ones: 0: Act during undervoltage fault 1: Do not act during undervoltage fault LED tens: 0: Act during automatic reset period 1: Do not act during automatic reset period	0x00	○
P11.14	Speed deviation detection value	0.0–50.0%	10.0%	○
P11.15	Speed deviation detection time	0.0–10.0s (Speed deviation protection is disabled when P11.15 is set to 0.0)	0.5s	○
P11.16	Automatic frequency reduction during voltage drop	0: Invalid 1: Valid	1	○

**P13 group SM control**

Function code	Name	Description	Default	Modify
P13.00	Pull-in current reduction coefficient	0.0–100.0%	50.0%	<input type="radio"/>
P13.01	Initial magnetic pole detection mode	0: Do not detection 1: High frequency superposition (reserved) 2: Pulse superposition (reserved)	0	<input checked="" type="radio"/>
P13.02	Pull-in current 1	0.0%–100.0% rated motor current	20.0%	<input type="radio"/>
P13.03	Pull-in current 2	0.0%–100.0% rated motor current	10.0%	<input type="radio"/>
P13.04	Switching frequency of pull-in current	0.00Hz–P00.03 (max. frequency)	30.00Hz	<input type="radio"/>
P13.05	High-frequency superposing frequency (reserved)	200Hz–1000Hz	500Hz	<input checked="" type="radio"/>
P13.06	High frequency superposing voltage	0.0–300.0% of the rated motor voltage	40.0%	<input checked="" type="radio"/>
P13.08	Control parameter 1	0–FFFF	0x120	<input type="radio"/>
P13.09	Control parameter 2	0–300.00	5.00	<input type="radio"/>
P13.11	Maladjustment detection time	Adjust the responsiveness of the function used to prevent maladjustment. Increase the value of P13.11 if load inertia is too large, however, the response speed will be impacted if the value is increased. Setting range: 0.0–10.0s	0.5s	<input type="radio"/>
P13.12	High-frequency compensation coefficient	When the motor runs at rated speed, this parameter is valid. If motor vibration occurs, adjust this parameter properly. Setting range: 0.0–100.0%	50.0%	<input type="radio"/>

**P14 group Serial communication**

Function code	Name	Description	Default	Modify
P14.00	Local communication address	1–247, 0 is broadcast address	2	<input type="radio"/>
P14.01	Communication baud rated setup	0: 1200BPS 1: 2400BPS 2: 4800BPS 3: 9600BPS 4: 19200BPS 5: 38400BPS	4	<input type="radio"/>

Function code	Name	Description	Default	Modify
P14.02	Data bit check setup	0: No parity check (N, 8, 1) for RTU 1: Even parity (E, 8, 1) for RTU 2: Odd parity (O, 8, 1) for RTU 3: No parity check (N, 8, 2) for RTU 4: Even parity (E, 8, 2) for RTU 5: Odd parity (O, 8, 2) for RTU	1	○
P14.03	Communication response delay	0–200ms	5ms	○
P14.04	Communication timeout fault time	0.0 (invalid), 0.1–60.0s	0.0s	○
P14.05	Transmission error processing	0–4 0: Alarm and coast to stop 1: Do not alarm and continue running 2: Do not alarm and stop as per stop mode (under communication control mode only) 3: Do not alarm and stop as per stop mode (under all control modes) 4: Alarm and coast to stop, and automatic fault reset after communication is restored	0	○
P14.06	Communication processing action selection	0x000–0x111 LED ones: write operation action 0: There is response for write operation 1: There is no response for write operation LED tens: Communication encryption processing 0: Communication encryption setting is invalid 1: Communication encryption setting is valid LED hundreds: Communication CRC check failure handling 0: Return error type 06 1: Do not return any data (This function is used with the Plot controller)	0x00	○

**P15 group Non-standard functions**

Function code	Name	Description	Default	Modify
P15.00	Auxiliary pressure start protection enable	0: Disable 1: Enable	0	◎

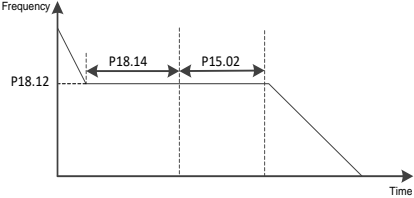
Function code	Name	Description	Default	Modify
P15.01	Auxiliary pressure start protection threshold	0.00–20.00MPa The VFD cannot start if present auxiliary pressure (P19.20) is greater than auxiliary pressure start protection threshold (P15.01).	0.30MPa	<input type="radio"/>
P15.02	Stop delay of auxiliary pressure start protection	0–300s When the auxiliary pressure start protection is enabled (P15.00=1), after the stopping delay (P18.14) is reached, if the present auxiliary pressure is still greater than the value set in P15.01, the VFD continues to keep running at no-load frequency in the time set in P15.02, and then stops. 	30s	<input type="radio"/>
P15.03	Pressure limit setting after time reached	0.00–P18.04MPa When the accumulated running time (P19.16) reaches the value set in P15.04, the pressure cannot exceed the value set in P15.03, if it exceeds, bit1 of P15.05 is set to 1.	0.50MPa	<input type="radio"/>
P15.04	Upper limit of accumulated running time	0–65535h The function is disabled when P15.04 is set to 0.	0	<input type="radio"/>
P15.05	Device status flag	Bit0: Auxiliary pressure high flag 0: None 1: Auxiliary pressure is high, and the VFD is not allowed to start Bit1: Max. set pressure limited flag 0: None 1: Function is limited, please contact the factory service.	0	<input checked="" type="radio"/>
P15.06	Auxiliary pressure detection delay	0–65535s <b>Note:</b> When P15.06 is set to 0, it indicates that auxiliary pressure too low fault is not detected.	0	<input type="radio"/>

Function code	Name	Description	Default	Modify
P15.07	Auxiliary pressure low protection point	0.00–20.00MPa When the auxiliary pressure protection is enabled (P18.39=1), if the auxiliary pressure is less than the value set in P15.07, the auxiliary pressure too low fault is reported. <b>Note:</b> When the compressor is in the sleeping state, the auxiliary pressure too low fault is not judged.	0.00	○
P15.08	Dynamic password	0–9999 <b>Note:</b> The dynamic password is automatically refreshed every power-on/every 8 hours/every time a new P15.09 value is written.	0000	●
P15.09	Handshake password	0–9999 <b>Note:</b> Handshake password (P15.09) is used to open or close the handshake protocol.	0000	◎
P15.10	Handshake timeout	0–65535s <b>Note:</b> If the handshake is still not successful after the time set in P15.10 is reached, the HAnd fault is reported, and no fault is reported when P15.10 is set to 0.	20s	○
P15.11	Handshake state	0–1 0: The handshake function is disabled. 1: The handshake function is enabled.	0	●
P15.12	Pressure decimal places	0–1 0: Two decimal places 1: Three decimal places	0	○

**P17 group Status viewing**

Function code	Name	Description	Default	Modify
P17.00	Setting frequency	0.00Hz–P00.03	0.00Hz	●
P17.01	Output frequency	0.00Hz–P00.03	0.00Hz	●
P17.02	Ramps reference frequency	0.00Hz–P00.03	0.00Hz	●
P17.03	Output voltage	0–1200V	0V	●
P17.04	Output current	0.0–3000.0A	0.0A	●
P17.05	Motor speed	0–65535RPM	0 RPM	●
P17.06	Torque current	-3000.0–3000.0A	0.0A	●
P17.07	Excitation current	-3000.0–3000.0A	0.0A	●

Function code	Name	Description	Default	Modify
P17.08	Motor power	-300.0%–300.0% (relative to rated motor power)	0.0%	●
P17.09	Output torque	-250.0–250.0%	0.0%	●
P17.10	Estimated motor frequency	0.00–P00.03	0.00Hz	●
P17.11	DC bus voltage	0.0–2000.0V	0V	●
P17.12	Digital input terminal state	0000–00FF	0	●
P17.13	Digital output terminal state	0000–000F	0	●
P17.16	Master fault code	0–43 (see P07.27–P07.32 for details)	0	●
P17.17	Reserved	0–38	0	●
P17.19	P1-input voltage	Display analog input voltage value of P1-channel, 2.00V–10.00V corresponds to 4–20mA; P05.32–P05.34 correspond to pressure 0.0–P18.04. If P1- input voltage is larger than 9.8V or less than 1V, it indicates pressure signal fault occurs. Range: 0.00–10.00V	0.00V	●
P17.20	PT1 input voltage	Display analog input voltage value of PT1 channel. Under air-compressor mode, connect to PT100 thermal resistor temperature sensor, different temperature generates different resistor value, and different resistor value corresponds to different input voltages, therefore, the input voltage value can correspond to corresponding detection temperature. Input voltage P18.28-P18.29 corresponds to -20°C to +150°C. Setting range: 0.00–10.00V	0.00V	●
P17.21	P2- input voltage	Display analog input voltage value of P2-channel, 2.00V–10.00V correspond to 4–20mA; P05.42–P05.44 correspond to pressure 0.0–P18.38. When the input voltage of P2- is larger than 9.8V or less than 1V, it indicates pressure signal fault occurs. Setting range: 0.00–10.00V	0.00V	●

Function code	Name	Description	Default	Modify
P17.22	PT2 input voltage	Display analog input voltage value of PT2 channel. Under air-compressor mode, connect to PT100 thermal resistor temperature sensor, different temperature generates corresponding resistor value, and different resistor value corresponds to corresponding input voltage, therefore, input voltage value can correspond to corresponding detection temperature. Input voltage P18.32–P18.33 correspond to -20°C to +150°C. Setting range: 0.00–10.00V	0.00V	●
P17.23	PID reference value	Display the set value of discharge pressure signal. 100% corresponds to the upper limit value of discharge pressure sensor (P18.04) (if P18.37=1, 100% corresponds to P18.38). Setting range: -100.0–100.0%	0.0%	●
P17.24	PID feedback value	Display the detection value of discharge pressure signal. Setting range: -100.0–100.0%	0.0%	●
P17.25	Motor power factor	-1.00–1.00	0.0	●
P17.26	Current running time	0–65535m	0m	●
P17.28	ASR controller output	-300.0%–300.0% (rated motor current)	0.0%	●
P17.29	Magnetic pole angle of SM	0.0–360.0	0.0	●
P17.30	Phase compensation quantity of SM	-180.0–180.0	0.0	●
P17.31	High-frequency superposition current of SM	0.0%–200.0%	0.0	●
P17.32	Flux linkage	0.0%–200.0%	0.0	●
P17.33	Exciting current reference	-3000.0–3000.0A	0.0	●
P17.34	Torque current reference	-3000.0–3000.0A	0.0	●
P17.35	AC incoming current	0.0–5000.0A	0.0	●
P17.36	Output torque	-3000.0Nm–3000.0Nm	0.0Nm	●

Function code	Name	Description	Default	Modify
P17.37	Motor overload count value	0–100 (OL1 fault is reported when the count value reaches 100)	0	●
P17.38	PID output value	Display the output value of PID control of discharge pressure signal; 100% corresponds to max. output frequency P00.03. Setting range: -100.00–100.00%	0.00%	●
P17.39	Warning code	0–41 Refer to the function description of P07.27.	0	●

**P18 group Functions only for air compressors**

Function code	Name	Description	Default	Modify
P18.00	Air compressor control mode	0: Normal VFD mode 1: Air-compressor control mode <b>Note:</b> When P18.00=1, P19 air-compressor state checking group is valid.	0	◎
P18.01	Sleep function selection		1	◎

Function code	Name	Description	Default	Modify
		0: Invalid 1: Automatic sleep mode 2: Manual sleep mode <b>Note:</b> When automatic sleep function is valid and unloading conditions are fulfilled, the VFD decelerates to P18.12 [no-load running frequency], and then, if discharge pressure is larger than P18.06 [loading pressure] during the time set by P18.13, the VFD will decelerate to P01.15 [stop speed] and then coast to stop to enter sleep stage. If the discharge pressure is less than loading pressure during P18.13, the VFD will perform loaded running again, and pressure PID will regulate accordingly. <b>Manual sleep:</b> Conduct manual sleep through the touch screen or other communication methods.		
P18.02	Loading/unloading mode	0: Automatic; 1: Manual When setting to manual state, after air compressor starts, loading/unloading manually; when setting to automatic mode, the air compressor loads/unloads automatically after starting.	0	○
P18.03	Temperature sensor channel	0: Machine head temperature PT 1, auxiliary temperature PT2 1: Machine head temperature PT 2, auxiliary temperature PT1 2: Temperature display in normal VFD mode (P18.00=0) (machine head temperature PT1, auxiliary temperature PT2)	1	◎
P18.04	Upper limit of pressure sensor P1	0.00–20.00 Mpa Related to the actual range of pressure sensor, the corresponding voltage of P18.04 is P05.34. <b>Note:</b> When restoring to default value, this value stays in currently set value.	1.60Mpa	◎
P18.05	Unloading pressure	Under automatic loading/unloading mode,	0.80Mpa	○

Function code	Name	Description	Default	Modify
P18.06	Loading pressure	when air compressor control is valid and the air compressor supplies air as normal, if the discharge pressure is higher than P18.05, unloading automatically. If sleep function is valid (P18.01=1), the VFD enters sleep state; if the discharge pressure is lower than P18.06, loading automatically. P18.07 is used to set the air-supply pressure when the air compressor runs stably. During load-carrying running, the motor speed is controlled by pressure PID, and the system keeps the discharge pressure constant via adjusting master speed. See 5.2 for details on pressure control process logic. Setting range: 0.00–P18.04	0.60Mpa	<input type="radio"/>
P18.07	Set pressure		0.70Mpa	<input type="radio"/>
P18.08	Starting temperature of the fan	When the machine head temperature is higher than P18.08, the fan starts;	75°C	<input type="radio"/>
P18.09	Stop temperature of the fan	When the machine head temperature is lower than P18.09, the fan stops;	65°C	<input type="radio"/>
P18.10	Setting temperature	P18.10 is used to set the target temperature of the machine head when the air compressor runs stably in dual-VFD mode, the fan speed is controlled by thermostatic PID (P18.42=0), PID calculation is carried out via P18.10 and the machine head temperature to realize thermostatic control. <b>Note:</b> Temperature PID is only for dual-VFD applications. The temperature PID of the main motor frequency conversion regulates the fan frequency conversion speed through analog output. Setting range: -20–150	75°C	<input type="radio"/>
P18.11	Lower-limit frequency at load-carrying running	P18.12–P00.04 (upper limit of running frequency) During the load-carrying running, the allowed min. working frequency is P18.11.	40.00Hz	<input type="radio"/>

Function code	Name	Description	Default	Modify
P18.12	No-load running frequency	P01.15–P18.11 (lower-limit frequency of load-carrying running) The output working frequency allowed during no-load of air compressor.	38.00 Hz	○
P18.13	No-load delay	When sleep function is valid, after unloading, the VFD runs at no-load frequency in the time set by P18.13, and then enters sleep state. When air consumption quantity is small, users can enable sleep function; if sleep function is valid, it is necessary to lower down P18.13 to make the device enter sleep state quicker. Setting range: 0–3600s	300s	○
P18.14	Stopping delay	After the stopping command becomes valid, the VFD will first run at no-load frequency in the time set by P18.14, and then stops. Setting range: 0–3600s	0s	○
P18.15	Loading delay	Loading operation is available only after the motor runs at no-load frequency in the time set by P18.15. Setting range: 0–3600s	10s	○
P18.16	Restart delay	After the system stops, it is necessary to wait until the time set by P18.16 elapsed before restart. Setting range: 0–3600s	30s	○
P18.17	Pre-alarm pressure	When current discharge pressure is higher than P18.17, the system indicates pressure pre-alarm by setting BIT8 of P19.13 to 1.	0.90Mpa	○
P18.18	Alarm pressure	When current discharge pressure is higher than P18.18, the system indicates pressure alarm by setting BIT10 of P19.13 to 1, and emergency-stop will be applied. Setting range: 0.00–P18.04	1.00Mpa	○
P18.19	Pre-alarm temperature	When machine head temperature is higher than P18.19, the system indicates temperature pre-alarm by setting BIT9 of P19.13 to 1.	105°C	○
P18.20	Alarm temperature		110°C	○
P18.21	Low-temperature protection threshold	When the machine head temperature is higher than P18.20, the system indicates temperature alarm by setting BIT11 of P19.13	-10°C	○

Function code	Name	Description	Default	Modify
		to 1, and emergency-stop will be applied. When machine head temperature is lower than P18.21, the system indicates low-temperature pre-alarm by setting BIT14 of P19.13 to 1, and air compressor cannot start. Setting range: -20–150		
P18.22	Power calibration coefficient	It is used to calibrate the displayed value of P19.10 [actual motor output power]. Setting range: 0%–200%	100%	<input type="radio"/>
P18.23	Temperature PID calculation cycle (Ts)	Set the sampling cycle of temperature PID. Setting range: 0.0–10.0s	2.0s	<input type="radio"/>
P18.24	Gain coefficient (kp)	It determines the regulation intensity of temperature PID regulator, the larger the value of kp, the stronger the regulation intensity, however, if it is too large, temperature oscillation may occur, users can fine-tune based on the default value. Setting range: 0.0–100.0	18.0	<input type="radio"/>
P18.25	Convergence coefficient (K)	It determines the converging speed of temperature PID regulator, the larger the value of K, the stronger the converging intensity, however, if it is too large, temperature oscillation may occur, users can fine-tune based on the default value. Setting range: 0.00–1.00	0.12	<input type="radio"/>
P18.26	Upper limit of temperature PID	It is used to limit the output value of temperature PID, of which 100% corresponds to the P00.03 max. output frequency of fan. Setting range: 0.00–100.00%	100.00%	<input type="radio"/>
P18.27	Lower limit of temperature PID		10.00%	<input type="radio"/>
P18.28	Lower limit voltage of PT1 (-20°C)	It is used to calibrate temperature detection circuit before shipment.  Connect to the resistor whose resistance is the same with that of PT100 at -20°C, read the voltage value of P17.20 and input it to P18.28.  Connect to the resistor whose resistance is the same with that of PT100 at 120°C, read the voltage value of P17.20 and input it to	3.10V	<input type="radio"/>
P18.29	Upper limit voltage of PT1 (120°C)		8.10V	<input type="radio"/>

Function code	Name	Description	Default	Modify
		P18.29. Setting range: 0.00–10.00V <b>Note:</b> This value will stay in currently set value when restoring to default values.		
P18.30	Pressure drop value of upper limit frequency	0.00–P18.04 When current pressure is larger than this pressure value, decrease the upper limit frequency (P18.04) as per the set value of P18.31.	0.70Mpa	○
P18.31	Drop rate of upper limit frequency	0.00Hz–10.00Hz When current pressure is larger than the pressure drop value of upper limit frequency (P18.30), this value is the reduction quantity of the corresponding upper limit frequency at every additional 0.01Mpa.	0.00Hz	○
P18.32	Lower limit voltage of PT2 (-20°C)	It is used to calibrate the temperature detection circuit:	3.10V	○
P18.33	Upper limit voltage of PT2 (120°C)	Connect to the resistor whose resistance is the same with that of PT100 at -20°C, read the voltage value of P17.22, and input it to P18.32. Connect to the resistor whose resistance is the same with that of PT100 at 150°C, read the voltage value of P17.22, and input it to P18.33. Setting range: 0.00–10.00V Note: When restoring to default values, this value will stay in current value.	8.10V	○
P18.34	Auxiliary temperature protection enable	0: Invalid 1: Valid	0	◎
P18.35	Auxiliary temperature pre-alarm	-20–150 When P18.34 is enabled and auxiliary temperature is higher than P18.35, the system indicates auxiliary temperature pre-alarm by setting BIT8 of P19.14 to 1.	105°C	○
P18.36	Auxiliary temperature alarm	-20–150 When P18.34 is enabled and auxiliary temperature is higher than P18.36, the system indicates auxiliary temperature alarm	110°C	○

Function code	Name	Description	Default	Modify
		by setting BIT10 of P19.14 to 1, and emergency-stop will be applied.		
P18.37	Pressure sensor channel	0: Discharge pressure P1, auxiliary pressure P2 1: Discharge pressure P2, auxiliary pressure P1 2: Pressure display in normal VFD mode (P18.00=0) (main pressure P1, auxiliary temperature P2)	0	⊙
P18.38	Upper limit of pressure sensor P2	0.00–20.00 Mpa It is related to the actual range of pressure sensor, the corresponding voltage of P18.04 is P05.44. <b>Note:</b> When restoring to default values, the value will stay in current value.	1.60Mpa	⊙
P18.39	Auxiliary pressure protection enable	0: Invalid 1: Valid	0	⊙
P18.40	Auxiliary pressure pre-alarm	0.00–20.00 When P18.39 is enabled and the auxiliary pressure is larger than P18.40, the system indicates auxiliary pressure pre-alarm by setting BIT7 of P19.14 to 1.	0.90Mpa	○
P18.41	Auxiliary pressure alarm	0.00–20.00 When P18.39 is enabled and the auxiliary pressure is larger than P18.41, the system indicates pressure alarm by setting BIT9 of P19.14 to 1, and emergency stop will be applied.	1.00Mpa	○
P18.42	Fan frequency reference mode	0: Temperature PID 1: Analog P2- setting 2: RS485 communication	0	⊙
P18.43	Fan control mode	0: Air compressor mode, the power-frequency fan starts/stops as per the temperature; 1: Terminal, the power-frequency fan starts/stops via terminals; 2: 485 communication (address 0X201B, write 1 to start, write 3 to stop)	0	⊙

Function code	Name	Description	Default	Modify
P18.44	Automatic frequency reduction threshold	0–120% Add automatic frequency reduction function. When the output current is larger than automatic frequency reduction threshold, it will adjust the output frequency via regulator to ensure the running current of the master is below the automatic frequency reduction threshold.	120%	<input type="radio"/>
P18.45	Maintenance timeout time	0–8000h When it is set to “0”, maintenance timeout function will be invalid. When it is set to a non-zero value, after parts maintenance pre-alarm is reported, if the VFD continues working until exceeding the value set by P18.45, the system will report maintenance timeout pre-alarm, and BIT11 of P19.14 will be set to “1”.	0	<input type="radio"/>

**P19 group Air compressor status viewing**

Function code	Name	Description	Default	Modify
P19.00	The set time of maintenance on part 1	P19.00–P19.04 displays the set time of maintenance on five kinds of parts. If the accumulated running time of the part exceeds the corresponding set value, the BIT of P19.14 will be set to 1 to indicate pre-alarms; if it is set to “0”, the running time pre-alarm will be invalid. P19.05–P19.09 displays the running time of corresponding parts. Range: 0–65535h	0	●
P19.01	The set time of maintenance on part 2		0	●
P19.02	The set time of maintenance on part 3		0	●
P19.03	The set time of maintenance on part 4		0	●
P19.04	The set time of maintenance on part 5		0	●
P19.05	Running time of part 1		0	●
P19.06	Running time of part 2		0	●
P19.07	Running time of part 3		0	●
P19.08	Running time of part 4		0	●
P19.09	Running time of part 5		0	●

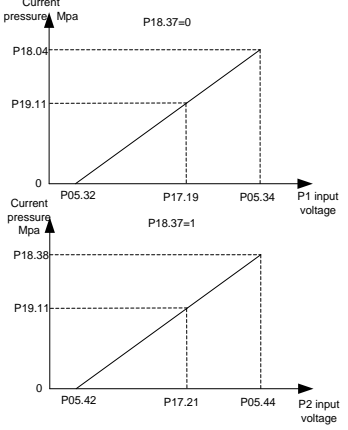
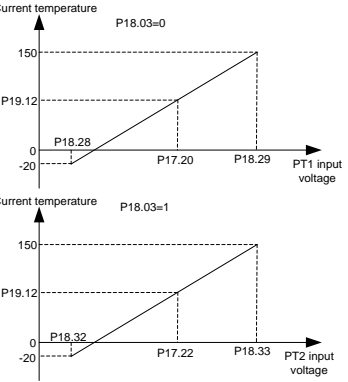
Function code	Name	Description	Default	Modify
P19.10	Actual output power of the motor	Display motor output power, it can be calibrated by P18.22. Range: 0.0–6553.5kW	0.0kW	●
P19.11	Present pressure	Display the discharge pressure value detected currently.  Range: 0.00–655.35Mpa	0.00Mpa	●
P19.12	Present temperature	Display the machine head temperature detected currently.  Range: -20–150°C	0°C	●
P19.13	Signal state 1	0000–0xFFFF BIT0: Air filter blockage signal 1: Fault; 0: Normal BIT1: Oil filter blockage signal	0	●

Function code	Name	Description	Default	Modify
		1: Fault; 0: Normal BIT2: Separator blockage signal 1: Fault; 0: Normal BIT3: Precision splitter blockage signal 1: Fault; 0: Normal BIT4: External fault signal 1 1: Fault; 0: Normal BIT5: External fault signal 2 1: Fault; 0: Normal BIT6: Solenoid valve signal state 1: Load; 0: Unload BIT7: Fan state 1: Run; 0: Stop BIT8: Pressure pre-alarm signal 1: Pressure pre-alarm; 0: Normal BIT9: Temperature pre-alarm signal 1: Temperature pre-alarm; 0: Normal BIT10: Pressure alarm signal 1: Pressure alarm; 0: Normal BIT11: Temperature alarm signal 1: Temperature alarm; 0: Normal BIT12: Pressure signal 1: Pressure signal fault; 0: Normal BIT13: Temperature signal 1: Temperature signal fault; 0: Normal BIT14: Low-temperature protection 1: Low-temperature alarm; 0: Normal BIT15: Master state 1: Run; 0: Stop		
P19.14	Signal state 2	0-0xFFFF BIT0: Maintenance reminder of part 1 1: Maintenance required; 0: Normal BIT1: Maintenance reminder of part 2 1: Maintenance required; 0: Normal BIT2: Maintenance reminder of part 3 1: Maintenance required; 0: Normal BIT3: Maintenance reminder of part 4 1: Maintenance required; 0: Normal BIT4: Maintenance reminder of part 5	0	●

Function code	Name	Description	Default	Modify
		1: Maintenance required; 0: Normal BIT5: Auxiliary pressure signal 1: Auxiliary pressure signal fault; 0: Normal BIT6: Auxiliary temperature signal 1: Auxiliary temperature signal fault; 0: Normal BIT7: Auxiliary pressure pre-alarm signal 1: Pressure pre-alarm; 0: Normal BIT8: Auxiliary temperature pre-alarm signal 1: Temperature pre-alarm; 0: Normal BIT9: Auxiliary pressure alarm signal 1: Pressure alarm; 0: Normal BIT10: Auxiliary temperature alarm signal 1: Temperature alarm; 0: Normal BIT11: Maintenance timeout remainder 1: Maintenance timeout remainder; 0: Normal BIT12: Phase sequence remainder 1: Fault; 0: Normal		
P19.15	Device state	0: Standby 1: Run 2: Fault 3: Emergency stop 4: Undervoltage 5: Alarm 6: Sleep 7: In stop 8: Restart delay	0	●
P19.16	Accumulated running time	Display range: 0–65535h	0	●
P19.17	Accumulated load-carrying running time		0	●
P19.18	Restart count-down	Display the remaining time of restart delay (P18.16). After the system stops, it will enter restart delay state and restart count-down to prevent immediate restart. After restart delay time is up, the system enters standby state. Under standby state, start command can be received. Setting range: 0–3600s	0s	●

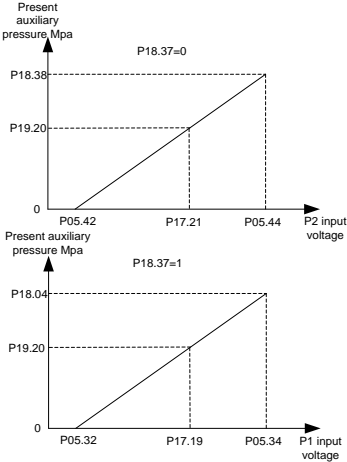
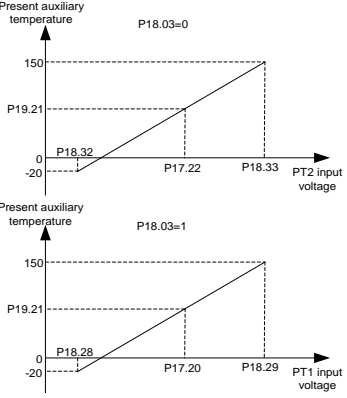
Function code	Name	Description	Default	Modify
P19.19	Output value of temperature PID	Display the output value of temperature PID regulation of machine head, 100% corresponds to P00.03 [the max. output frequency of the fan]. Setting range: 0.00–100.00%	0.00%	●
P19.20	Present auxiliary pressure	Display the auxiliary pressure value detected at present.  Range: 0.00–655.35Mpa	0.00Mpa	●
P19.21	Present auxiliary temperature	Display the auxiliary temperature value detected at present.  Range: -20–150°C	0°C	●

Function code	Name	Description	Default	Modify
P19.22	Input power phase sequence state	If the VFD enables phase sequence detection and input phase loss hardware protection, corresponding fault will be reported when negative sequence and any phase loss occurs; otherwise, fault will not be reported. 0: Positive sequence 1: Negative sequence 2: R phase loss 3: S phase loss 4: T phase loss	0	●
P19.23	State of phase sequence detection flat cable	0: Normal, indicating the flat cable is plugged in properly 1: Abnormal, indicating the flat cable is not plugged in	0	●

**P21 group Power-frequency fan protection**

Function code	Name	Description	Default	Modify
P21.00	Rated fan current	0.0–40.0A This function code is related to current detection and overload protection function of power-frequency fan. Set to 0 will disable this function.	0.0A	○
P21.01	Current transformation ratio of the fan	1.0–4000.0	200 (≤15kW); 1000 (≥18.5kW)	○
P21.03	Current imbalance coefficient	1.00–3.00 Among the current of three phases of the fan, if the ratio between max. current and min. current is larger than P21.03, the VFD displays fan current imbalance fault.	3.0	○
P21.04	Calibration coefficient of A phase current of the fan	0.0–150.0% Actual current=display current*current calibration coefficient	100.0%	○
P21.05	Calibration coefficient of B phase current of the fan	<b>Note:</b> When restoring to default values, this value will stay in currently set value.	100.0%	○

Function code	Name	Description	Default	Modify
P21.06	Calibration coefficient of C phase current of the fan		100.0%	<input type="radio"/>
P21.07	User-defined fault action selection 1	Ones: Motor overload (OL1) 0: Coast to stop 1: Runs at alternative frequency of P21.10 Tens: Electronic overload (OL3) 0: Process as per P11.08 1: Run at alternative frequency of P21.10 Hundreds: Rectifier module overheat (OH1) 0: Coast to stop 1: Run at alternative frequency of P21.10 Thousands: Inverter module overheat fault (OH2) 0: Coast to stop 1: Run at alternative frequency of P21.10	0x0000	<input type="radio"/>
P21.08	User-defined fault action selection 2	Ones: Underload (LL) 0: Process as per P11.08 1: Run at alternative frequency of P21.10 Tens: External fault 1 signal 0: Coast to stop 1: Run at alternative frequency of P21.10 Hundreds: External fault 2 signal 0: Coast to stop 1: Run at alternative frequency of P21.10 Thousands: Reserved 0: Coast to stop 1: Run at alternative frequency of P21.10	0x0000	<input type="radio"/>
P21.09	User-defined fault action selection 3	Ones: 485 communication fault (CE) 0: Coast to stop 1: Run at alternative frequency of P21.10 Tens: EEPROM operation fault (EEP) 0: Coast to stop 1: Run at alternative frequency of P21.10 Hundreds: Current overload of power-frequency fan (OLF) 0: Coast to stop 1: Run at alternative frequency of P21.10 Thousands: 3PH current imbalance of	0x0000	<input type="radio"/>

Function code	Name	Description	Default	Modify
		power-frequency fan (SPOF) 0: Coast to stop 1: Run at alternative frequency of P21.10		
P21.10	Alternative frequency	0.0–100.0% (max. output frequency)	50.0%	○
P21.11	Running time of alternative frequency	0.0–6000.0s <b>Note:</b> When user-defined fault occurs to the VFD, if the fault persists after the VFD continues running at alternative frequency of P21.10 in the time set by P21.11, the VFD will coast to stop; if the fault no longer occurs during P21.11, the VFD restores to normal mode.	60.0s	○
P21.13	Display current of A phase of the fan	0.0–40.0A	0.0A	●
P21.14	Display current of B phase of the fan	0.0–40.0A	0.0A	●
P21.15	Display current of C phase of the fan	0.0–40.0A	0.0A	●
P21.20	Fan state	0X0000–0XFFFF Bit0: when it is 1, it means power-frequency fan is started	0x0000	●

### 5.2 Control logic of the air compressor

(1) The following figure shows the control logic of the air compressor.

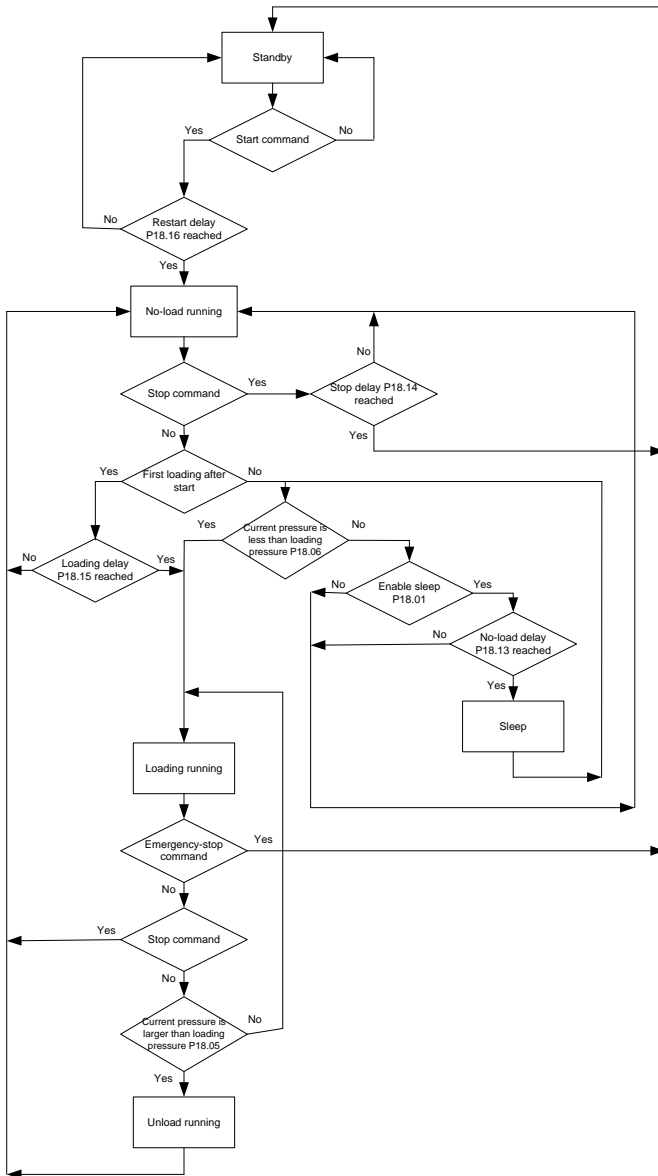

(2) The following figure shows the pressure and running frequency control during the running of the air compressor.

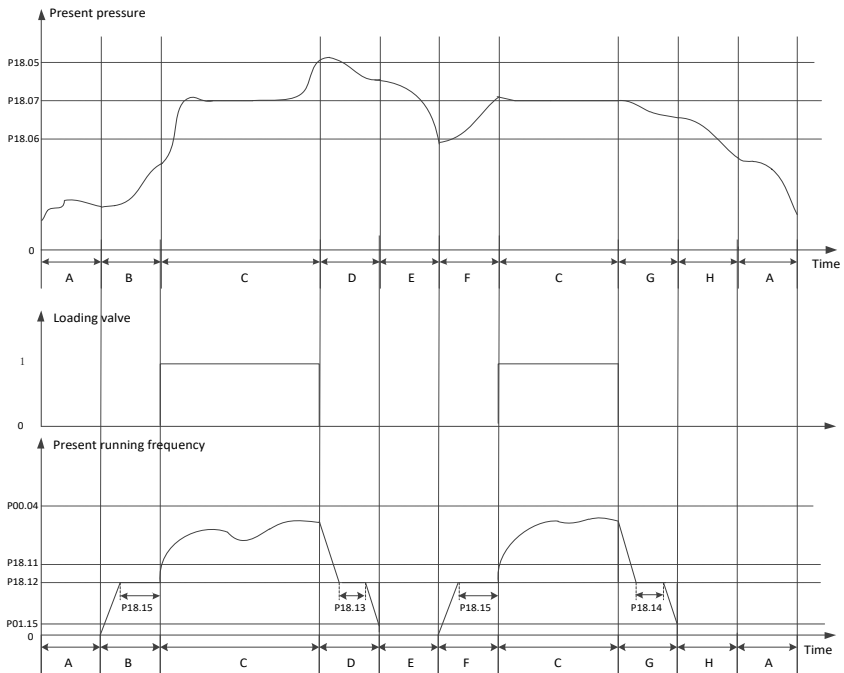

In above figure, P18.05 is unloading pressure; P18.06 is loading pressure; P18.07 is the set pressure. P00.04 is upper limit frequency, P18.11 is lower limit value of load-carrying running frequency, P18.12 is no-load frequency, P01.15 is stop speed. Description of A-H stage control process is shown below:

- A: Standby state
- B: Starting stage of startup, duration is P18.15 (including part of the acceleration time P00.11);
- C: Constant discharge stage of loading, pressure PID regulation is valid;
- D: Unloading stage, duration includes part of deceleration time P00.12 and P18.13;
- E: Sleep stage, the VFD does not run;
- F: Starting stage of wake-up, duration is P18.15 (including part of the acceleration time P00.11);
- G: Starting stage of stop, duration includes part of deceleration time P00.12 and P18.14;
- H: Restart delay stage after stop, duration is P18.16.

When air compressor control is valid and under automatic loading/unloading mode, the air

compressor enters normal air supply state after starts. When the discharge pressure is higher than P18.05, automatic unloading will be applied, and the VFD enters sleep state. If sleep function is invalid, the VFD will continue running at no-load frequency P18.12. When the discharge pressure is lower than P18.06, automatic loading will be applied, and during load-carrying running, the master speed is controlled by pressure PID. P18.07 is used to set the air supply pressure when the air compressor runs stably. The VFD keeps the discharge pressure constant by regulating the master speed. Constant-pressure control adopts PID algorithm, and the frequency reference source of the master is set by P00.06=7, the PID reference source selects P09.00 = 10, reference pressure is set via P18.07. The feedback source of PID P09.02 = 8, which is obtained by detecting the pressure signal. PID parameter P9.04, P9.05 and P9.06 adopts system default values.

**Note:** In above figure, the VFD stops as per P01.08, default setting is decelerate to stop.

Normal stop command and unloading stage are deceleration process; the VFD will change to coast to stop during emergency-stop operation and faults.

### 5.3 PID commissioning

PID control, a common mode for process control, is mainly used to adjust the VFD output frequency or output voltage through performing scale-division, integral and differential operations on the difference between feedback signal of controlled variables and signal of the target, thus forming a negative feedback system to keep the controlled variables above the target. It is suitable for flow control, pressure control, temperature control, etc. Diagram of basic principles for output frequency regulation is shown in the figure below.

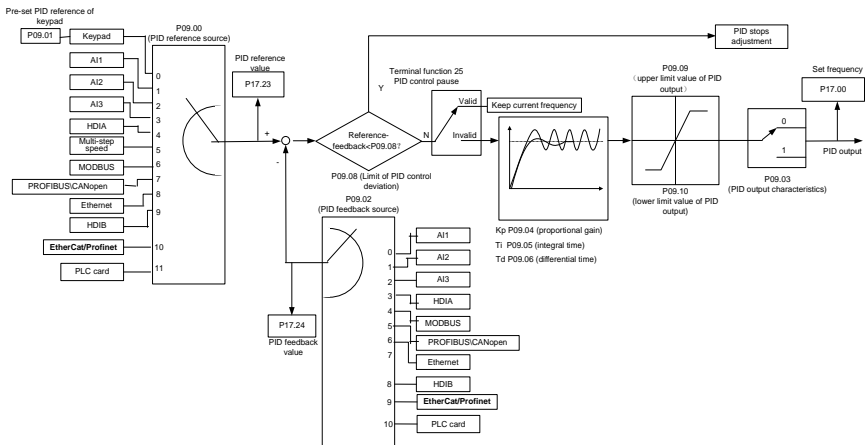

Introduction to the working principles and control methods for PID control:

**Proportional control (Kp):** When the feedback deviates from the reference, the output will be proportional to the deviation, if such deviation is constant, the regulating variable will also be constant. Proportional control can respond to feedback changes rapidly, however, it cannot eliminate the error by itself. The larger the proportional gain, the faster the regulating speed, but too large gain will result

in oscillation. To solve this problem, first, set the integral time to a large value and the derivative time to 0, and run the system by proportional control, and then change the reference to observe the deviation between feedback signal and the reference (static difference), if the static difference is (e.g., increase the reference, and the feedback variable is always less than the reference after system stabilizes), continue increasing the proportional gain, otherwise, decrease the proportional gain; repeat such process until the static error becomes small.

Integral time (Ti): When feedback deviates from reference, the output regulating variable accumulates continuously, if the deviation persists, the regulating variable will increase continuously until deviation disappears. Integral regulator can be used to eliminate static difference; however, too large regulation may lead to repetitive overshoot, which will cause system instability and oscillation. The feature of oscillation caused by strong integral effect is that the feedback signal fluctuates up and down based on the reference variable, and fluctuation range increases gradually until oscillation occurred. Integral time parameter is generally regulated gradually from large to small until the stabilized system speed fulfills the requirement.

Derivative time (Td): When the deviation between feedback and reference changes, output the regulating variable which is proportional to the deviation variation rate, and this regulating variable is only related to the direction and magnitude of the deviation variation rather than the direction and magnitude of the deviation itself. Differential control is used to control the feedback signal variation based on the variation trend. Differential regulator should be used with caution as it may easily enlarge the system interferences, especially those with high variation frequency.

### 5.3.1 General procedures for PID parameter settings

#### a. Determining proportional gain P

When determining proportional gain P, first, remove the integral term and derivative term of PID by making  $T_i=0$  and  $T_d=0$  (see PID parameter setup for details), thus turning PID into pure proportional control. Set the input to 60%–70% of the max. allowable value, and increase proportional gain P gradually from 0 until system oscillation occurred, and then in turn, decrease proportional gain P gradually from current value until system oscillation disappears, record the proportional gain P at this point and set the proportional gain P of PID to 60%–70% of current value. This is whole commissioning process of proportional gain P.

#### b. Determine integral time Ti

After proportional gain P is determined, set the initial value of a larger integral time  $T_i$ , and decrease  $T_i$  gradually until system oscillation occurred, and then in turn, increase  $T_i$  until system oscillation disappears, record the  $T_i$  at this point, and set the integral time constant  $T_i$  of PID to 150%–180% of current value. This is the commissioning process of integral time constant  $T_i$ .

#### c. Determining derivative time Td

The derivative time  $T_d$  is generally set to 0.

If you need to set  $T_d$  to another value, set in the same way with P and  $T_i$ , namely set  $T_d$  to 30% of the value when there is no oscillation.

d. Empty system load, perform load-carrying joint debugging, and then fine-tune PID parameter until fulfilling the requirement.

### 5.3.2 PID adjusting methods

After setting the parameters controlled by PID, you can adjust these parameters by the following means.

**Control overshoot:** When overshoot occurred, shorten the derivative time ( $T_d$ ) and prolong integral time ( $T_i$ ).

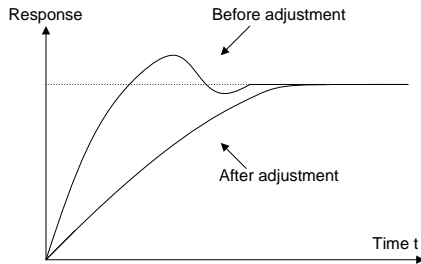

**Stabilize the feedback value as fast as possible:** When overshoot occurred, shorten integral time ( $T_i$ ) and prolong derivative time ( $T_d$ ) to stabilize control as fast as possible.

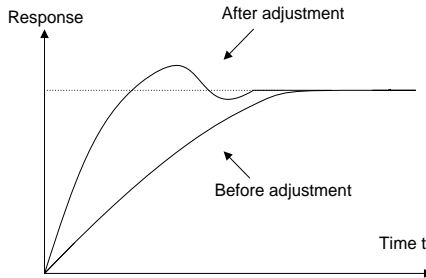

**Control long-term vibration:** If the cycle of periodic vibration is longer than the set value of integral time ( $T_i$ ), it indicates the integral action is too strong, prolong the integral time ( $T_i$ ) to control vibration.

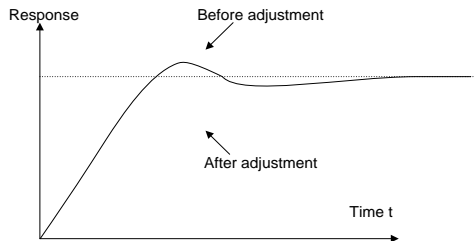

**Control short-term vibration:** If the vibration cycle is short and almost the same with the set value of derivative time ( $T_d$ ), it indicates derivative action is too strong, shorten the derivative time ( $T_d$ ) to

control vibration. When derivative time (Td) is set to 0.00 (namely no derivative control), and there is no way to control vibration, decrease the proportional gain.

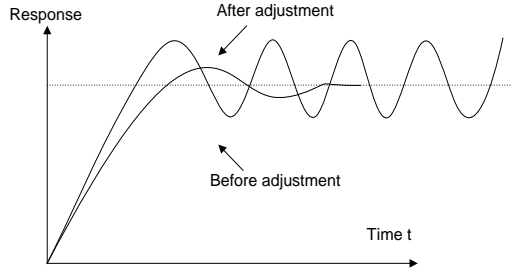

Related parameter list:

Function code	Name	Description	Default
P09.00	PID reference source	0: Keypad digits (P09.01) 1: Analog P1- 2: Reserved 3: Analog P2- 4: Reserved 5: Multi-step 6: Modbus communication 7-9: Reserved 10: Pressure setting of dedicated function of air compressor	0
P09.01	PID reference preset through keypad	-100.0%~100.0%	0.0%
P09.02	PID feedback source	0: Analog P1- 1: Reserved 2: Analog P2- 3: Reserved 4: Modbus communication 5-7: Reserved 8: Pressure feedback of dedicated function of air compressor	0
P09.03	PID output characteristics selection	0: PID output characteristic is positive: the feedback signal is larger than PID reference, which requires the VFD output frequency to decrease to balance PID, e.g. tension PID control of winding.	0

Function code	Name	Description	Default
		1: PID output characteristic is negative: feedback signal is larger than PID reference, which requires the VFD output frequency to increase to balance PID, e.g. tension PID control of unwinding.	
P09.04	Proportional gain (Kp)	It determines the regulation intensity of the whole PID regulator, the larger the P is, the stronger the regulation intensity is. If this parameter is 100, it means the regulation amplitude made on output frequency command by the proportional regulator (ignoring integral and differential actions) is the max. output frequency (P00.03) when the deviation between PID feedback quantity and reference quantity is 100%. Setting range: 0.00–100.00	10.00
P09.05	Integral time (Ti)	It determines the speed of integral regulation made on the deviation between PID feedback quantity and reference quantity by PID regulator. When the deviation between PID feedback quantity and reference quantity is 100%, the regulation quantity (ignoring proportional and differential actions) of integral regulator can reach max. output frequency (P00.03) through continuous regulation in the time set by P09.05. The shorter the integral time, the stronger the regulation intensity. Setting range: 0.01–10.00s	2.00s
P09.06	Differential time (Td)	It determines the intensity of variation regulation made on the deviation between PID feedback quantity and reference quantity by PID regulator. If the feedback quantity changes by 100% during the time set by P09.06, the regulation quantity of differential regulator (ignoring proportional and integral actions) is the max. output frequency (P00.03). The longer the differential time, the stronger the regulation intensity. Setting range: 0.00–10.00s	1.00s
P09.07	Sampling cycle (T)	It means the sampling cycle of feedback quantity. The regulator calculates once during each	0.100s

Function code	Name	Description	Default
		sampling cycle. The longer the sampling cycle, the slower the response speed. Setting range: 0.001–10.000s	
P09.08	Final limit of PID control deviation	It means the max. allowed deviation quantity of the PID system feedback value relative to closed-loop reference value. Within the deviation limit, PID regulator stops regulating, this parameter can be used to regulate the precision and stability of PID system. Setting range: 0.0–100.0%	0.1%
P09.09	Upper limit value of PID output	P09.10–100.0% (max. frequency)	100.0%
P09.10	Lower limit value of PID output	-100.0%–P09.09 (max. frequency)	0.0%
P09.11	Feedback offline detection value	0.0–100.0%	0.0%
P09.12	Feedback offline detection time	0.0–3600.0s	1.0s
P09.13	PID regulation selection	0x00–0x11 LED ones: 0: Continue integral regulation when the frequency reaches upper/lower limit 1: Stop integral regulation when the frequency reaches upper/lower limit LED tens: 0: The same with the main set direction 1: Contrary to the main set direction	0x01
P17.00	Set frequency	0.00Hz–P00.03 (max. output frequency)	0.00Hz
P17.23	PID reference value	Display the set value of discharge pressure signal. 100% corresponds to the upper limit value of discharge pressure sensor (P18.04) (if P18.37=1, 100% corresponds to P18.38). Setting range: -100.0–100.0%	0.0%
P17.24	PID feedback value	Display the detection value of discharge pressure signal. Setting range: -100.0–100.0%	0.0%

### 5.4 Operating logic of blower oil pump

Dedicated function of the blower oil pump: RO terminal is enabled after the VFD start command is received, the VFD starts after start delay time (P01.23) is reached and stops after the VFD stop command is received. RO terminal closes output after corresponding switch-off delay time is reached. For details about "RO switch-off delay" in the following figure, refer to P06 group function parameters, and set the corresponding RO switch-off delay function code according to the current RO terminal.

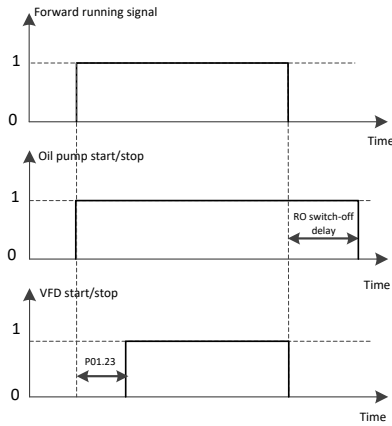

## Chapter 6 Fault information and troubleshooting

### 6.1 VFD faults and solutions

**Note:** The numbers enclosed in square brackets such as [1], [2] and [3] in the Fault type column in the following table indicate the VFD fault type codes read through communication.

Fault code	Fault type	Possible cause	Solution
OUt1	[1] Inverter unit U phase protection	<ul style="list-style-type: none"> <li>Acceleration is too fast.</li> <li>Internal damage occurs to the IGBT of this phase.</li> <li>Misacts caused by interference.</li> <li>Drive wires are connected improperly.</li> <li>Short-circuited to ground.</li> </ul>	<ul style="list-style-type: none"> <li>Increase acceleration time.</li> <li>Replace power unit.</li> <li>Check the drive wires.</li> <li>Check whether peripheral equipment suffers from strong interference source.</li> </ul>
OUt2	[2] Inverter unit V phase protection		
OUt3	[3] Inverter unit W phase protection		
OC1	[4] Overcurrent at acceleration	<ul style="list-style-type: none"> <li>Acceleration or deceleration is too fast.</li> <li>Grid voltage is too low.</li> <li>VFD power is too low.</li> <li>Load transients or is abnormal.</li> <li>Short-circuited to ground, output phase loss.</li> <li>There is strong external interference.</li> </ul>	<ul style="list-style-type: none"> <li>Increase acceleration /deceleration time.</li> <li>Check the input power.</li> <li>Adopt the VFD with a larger power.</li> <li>Check if the load is short circuited (short circuited to ground or between wires) or stall occurs.</li> <li>Check the output wiring.</li> <li>Check if there is strong interference.</li> </ul>
OC2	[5] Overcurrent at deceleration		
OC3	[6] Overcurrent at constant speed		
OV1	[7] Overvoltage at acceleration	<ul style="list-style-type: none"> <li>The input voltage is abnormal.</li> <li>There is large energy feedback.</li> </ul>	<ul style="list-style-type: none"> <li>Check the input power.</li> <li>Check if the deceleration time of the load is too short or the motor starts during the rotating, or dynamic brake units needs to be installed.</li> </ul>
OV2	[8] Overvoltage at deceleration		
OV3	[9] Overvoltage at constant speed		
UV	[10] Bus undervoltage fault	<ul style="list-style-type: none"> <li>Grid voltage is too low.</li> </ul>	<ul style="list-style-type: none"> <li>Check the grid input power.</li> </ul>
OL1	[11] Motor overload	<ul style="list-style-type: none"> <li>Grid voltage is too low.</li> <li>Rated motor current is set improperly.</li> <li>Motor stalls or load</li> </ul>	<ul style="list-style-type: none"> <li>Check grid voltage.</li> <li>Reset rated motor current.</li> <li>Check load and adjust torque boost quantity</li> </ul>

Fault code	Fault type	Possible cause	Solution
		transients	
OL2	[12] VFD overload	<ul style="list-style-type: none"> <li>● Acceleration is too fast.</li> <li>● The motor is restarted during rotating.</li> <li>● The grid voltage is too low.</li> <li>● The load is too large.</li> </ul>	<ul style="list-style-type: none"> <li>● Increase acceleration time.</li> <li>● Restart the motor after stop.</li> <li>● Check grid voltage.</li> <li>● Adopt the VFD with a larger power.</li> <li>● Select a proper motor.</li> </ul>
SPI	[13] Phase loss on input side	<ul style="list-style-type: none"> <li>● Phase loss or fluctuation occurs to input R, S and T.</li> </ul>	<ul style="list-style-type: none"> <li>● Check input power.</li> <li>● Check installation wiring.</li> </ul>
SPO	[14] Phase loss on output side	<ul style="list-style-type: none"> <li>● Phase loss output occurs to U, V and W (or serious 3PH imbalance occurs to the load).</li> </ul>	<ul style="list-style-type: none"> <li>● Check the output wiring.</li> <li>● Check the motor and cable.</li> </ul>
OH1	[15] Overheat of rectifier module	<ul style="list-style-type: none"> <li>● Air duct blocked or fan damaged.</li> </ul>	<ul style="list-style-type: none"> <li>● Ventilate the air duct or replace the fan.</li> <li>● Lower down the ambient temperature.</li> </ul>
OH2	[16] Overheat of inverter module	<ul style="list-style-type: none"> <li>● Ambient temperature is too high.</li> <li>● Long-time overload running.</li> </ul>	
EF	[17] External fault	<ul style="list-style-type: none"> <li>● S external fault input terminal acts.</li> </ul>	<ul style="list-style-type: none"> <li>● Check external equipment input.</li> </ul>
CE	[18] 485 communication fault	<ul style="list-style-type: none"> <li>● Baud rate is set improperly.</li> <li>● Communication line fault.</li> <li>● Communication address error.</li> <li>● Communication suffers strong interference.</li> </ul>	<ul style="list-style-type: none"> <li>● Set proper baud rate.</li> <li>● Check the wiring of communication interface.</li> <li>● Check the wiring of communication interfaces.</li> <li>● Set correct communication address.</li> <li>● Replace or change the wiring to improve anti-interference capacity.</li> </ul>
ItE	[19] Current detection fault	<ul style="list-style-type: none"> <li>● Poor contact of controller board connector.</li> <li>● Hall components are damaged.</li> <li>● Amplifying circuit is abnormal.</li> </ul>	<ul style="list-style-type: none"> <li>● Check the connector and re-plug wires.</li> <li>● Replace the hall.</li> <li>● Replace the main control board.</li> </ul>
tE	[20] Motor autotuning fault	<ul style="list-style-type: none"> <li>● Motor capacity does not match VFD capacity.</li> </ul>	<ul style="list-style-type: none"> <li>● Change the VFD model.</li> <li>● Set motor type and</li> </ul>

Fault code	Fault type	Possible cause	Solution
		<ul style="list-style-type: none"> <li>● Motor parameters are set improperly.</li> <li>● The deviation between the parameters obtained from autotuning and the standard parameter is huge.</li> <li>● Autotuning timeout.</li> </ul>	<p>nameplate parameters correctly.</p> <ul style="list-style-type: none"> <li>● Empty the motor load and identify again.</li> <li>● Check the motor wiring and parameter setup.</li> <li>● Check whether upper limit frequency is larger than 2/3 of the rated frequency.</li> </ul>
EEP	[21] EEPROM operation fault	<ul style="list-style-type: none"> <li>● Error occurred to the writing/reading of control parameters.</li> <li>● EEPROM damaged.</li> </ul>	<ul style="list-style-type: none"> <li>● Press <b>STOP/RST</b> to reset.</li> <li>● Replace the main control board.</li> </ul>
PIDE	[22] PID feedback offline fault	<ul style="list-style-type: none"> <li>● PID feedback offline.</li> <li>● PID feedback source disappears</li> </ul>	<ul style="list-style-type: none"> <li>● Check PID feedback signal wire.</li> <li>● Check PID feedback source</li> </ul>
END	[24] Running time is up	<ul style="list-style-type: none"> <li>● The actual running time of the VFD is larger than the internally set time.</li> </ul>	<ul style="list-style-type: none"> <li>● Ask supplier for help.</li> <li>● Adjust the set running time.</li> </ul>
OL3	[25] Electronic overload fault	<ul style="list-style-type: none"> <li>● The VFD reports overload pre-alarm according to the set value.</li> </ul>	<ul style="list-style-type: none"> <li>● Check the load and overload pre-alarm threshold.</li> </ul>
PCE	[26] Keypad communication fault	<ul style="list-style-type: none"> <li>● Keypad wire is poorly contacted or disconnected.</li> <li>● Keypad wire is too long and suffers strong interference.</li> <li>● Keypad or communication circuit is faulty.</li> </ul>	<ul style="list-style-type: none"> <li>● Check the keypad wire and confirm whether fault exists.</li> <li>● Check the environment and rule out interference source.</li> <li>● Replace the hardware, and ask for maintenance service.</li> </ul>
UPE	[27] Parameter upload error	<ul style="list-style-type: none"> <li>● Keypad line is poorly contacted or disconnected.</li> <li>● Keypad wire is too long or suffers strong interference.</li> <li>● Keypad or mainboard communication circuit is faulty.</li> </ul>	<ul style="list-style-type: none"> <li>● Check the environment and rule out the interference source.</li> <li>● Replace the hardware, ask for maintenance service.</li> <li>● Replace the hardware, ask for maintenance service.</li> </ul>

Fault code	Fault type	Possible cause	Solution
DNE	[28] Parameter download error	<ul style="list-style-type: none"> <li>● Keypad line is poorly contacted or disconnected.</li> <li>● Keypad wire is too long or suffers strong interference.</li> <li>● Storage data in the keypad is wrong.</li> </ul>	<ul style="list-style-type: none"> <li>● Check the environment and rule out the interference source.</li> <li>● Replace the hardware, ask for maintenance service.</li> <li>● Re-copy the data in the keypad.</li> </ul>
ETH1	[32] To-ground short circuit fault 1	<ul style="list-style-type: none"> <li>● VFD output is short circuited to ground.</li> <li>● Current detection circuit is faulty.</li> <li>● Actual motor power setup differs sharply from the VFD power.</li> </ul>	<ul style="list-style-type: none"> <li>● Check whether motor wiring is normal/motor is short circuited to ground.</li> <li>● Replace the hall.</li> <li>● Replace main control board/drive board.</li> <li>● Reset correct motor parameters.</li> </ul>
ETH2	[33] To-ground short circuit fault 2		
dEu	[34] Speed deviation fault	<ul style="list-style-type: none"> <li>● Load is too heavy or stall.</li> </ul>	<ul style="list-style-type: none"> <li>● Check the load and ensure it is normal, increase the detection time.</li> <li>● Check whether control parameters are proper.</li> </ul>
STo	[35] Maladjustment fault	<ul style="list-style-type: none"> <li>● Control parameters of synchronous motor is set improperly.</li> <li>● Autotuning parameters are inaccurate.</li> <li>● VFD is not connected to the motor.</li> </ul>	<ul style="list-style-type: none"> <li>● Check the load and ensure the load is normal.</li> <li>● Check whether control parameters are set correctly.</li> <li>● Increase maladjustment detection time.</li> </ul>
LL	[36] Electronic underload fault	<ul style="list-style-type: none"> <li>● The VFD reports underload pre-alarm according to the set value.</li> </ul>	<ul style="list-style-type: none"> <li>● Detect the load and underload pre-alarm threshold.</li> </ul>
PSF	[38] Phase sequence fault	<ul style="list-style-type: none"> <li>● The phase sequence on power input side is negative.</li> </ul>	<ul style="list-style-type: none"> <li>● Swop any two of the power input cables.</li> </ul>
SPOF	[39] 3PH current imbalance of power-frequency fan	<ul style="list-style-type: none"> <li>● Phase loss occurs to 3PH wiring of the fan.</li> <li>● Stator winding of 3PH of the fan is abnormal.</li> <li>● Poor grid quality.</li> </ul>	<ul style="list-style-type: none"> <li>● Check whether the fan is disconnected or poorly wiring of the fan.</li> <li>● Measure whether the 3PH winding impedance of the fan is balanced.</li> </ul>

Fault code	Fault type	Possible cause	Solution
			<ul style="list-style-type: none"> <li>● Increase the set value of P21.03 properly to lower down the sensitivity during determining imbalance degree.</li> </ul>
OLF	[40] Current overload of power-frequency fan	<ul style="list-style-type: none"> <li>● Rated fan current is set improperly.</li> <li>● Fan power is too small.</li> <li>● Fan stalls.</li> </ul>	<ul style="list-style-type: none"> <li>● Check whether the set value of P21.00 is the same with the rated current of the fan nameplate. whether the current transformation ratio P21.01 is the same with current transformer nameplate.</li> <li>● Actually detected fan current is too large, it is recommended to increase the power.</li> <li>● Check whether the fan stalls.</li> </ul>
ENC1O	[41] Encoder offline	<ul style="list-style-type: none"> <li>● Encoder line sequence error.</li> <li>● Encoder damaged.</li> </ul>	<ul style="list-style-type: none"> <li>● Check encoder wiring.</li> <li>● Check whether the pulse number setting of P20.01 encoder is set correctly.</li> <li>● Replace the encoder.</li> </ul>
ENC1D	[42] Encoder reversal	<ul style="list-style-type: none"> <li>● Encoder speed signal is contrary to the motor running direction.</li> </ul>	<ul style="list-style-type: none"> <li>● Reset P20.02 encoder direction.</li> </ul>
ENC1Z	[43] Encoder Z pulse offline	<ul style="list-style-type: none"> <li>● Z signal wire disconnected.</li> </ul>	<ul style="list-style-type: none"> <li>● Check the wiring of Z signal wire.</li> </ul>
L-AUP	[44] Auxiliary pressure too low	<ul style="list-style-type: none"> <li>● Auxiliary pressure is too low at start-up.</li> </ul>	<ul style="list-style-type: none"> <li>● Check whether P15.06 and P15.07 are set properly.</li> </ul>
HAnd	[45] Dynamic handshake failure	<ul style="list-style-type: none"> <li>● Handshake process timeout.</li> </ul>	<ul style="list-style-type: none"> <li>● Check whether the handshake between the Plot controller and VFD is performed according to the handshake protocol.</li> <li>● Check whether P15.10 is set properly.</li> </ul>

## 6.2 Fault contents and solutions of air compressor equipment

Abnormal state and solutions of air compressor equipment:

P19.13	State type	Possible cause	Solution
BIT0=1	Air filter blocked	<ul style="list-style-type: none"> <li>● Air filter is abnormal.</li> </ul>	<ul style="list-style-type: none"> <li>● Check air filter after stop.</li> </ul>
BIT1=1	Oil filter blocked	<ul style="list-style-type: none"> <li>● Oil filter is abnormal.</li> </ul>	<ul style="list-style-type: none"> <li>● Check oil filter after stop.</li> </ul>
BIT2=1	Separator blocked	<ul style="list-style-type: none"> <li>● Separator is abnormal.</li> </ul>	<ul style="list-style-type: none"> <li>● Check the separator after stop.</li> </ul>
BIT3=1	Precision splitter blocked	<ul style="list-style-type: none"> <li>● Precision splitter is abnormal.</li> </ul>	<ul style="list-style-type: none"> <li>● Check the precision splitter after stop.</li> </ul>
BIT8=1	Pressure pre-alarm	<ul style="list-style-type: none"> <li>● Actual voltage is detected by P1 to be larger than the pre-alarm voltage set by P18.17.</li> </ul>	<ul style="list-style-type: none"> <li>● Check whether solenoid valve is normal.</li> <li>● Check whether pressure control parameters are set correctly.</li> </ul>
BIT9=1	Temperature pre-alarm	<ul style="list-style-type: none"> <li>● Actual temperature detected by PT1 is higher than the pre-alarm temperature set by P18.19.</li> </ul>	<ul style="list-style-type: none"> <li>● Check whether fan control parameters are set correctly.</li> <li>● Whether the fan operates normally.</li> <li>● Fan power is too small to dissipate heat effectively.</li> <li>● Check whether there is lubricating oil.</li> </ul>
BIT10=1	Pressure alarm	<ul style="list-style-type: none"> <li>● Actual voltage detected by P1 is larger than the alarm voltage set by P18.18.</li> </ul>	<ul style="list-style-type: none"> <li>● Check whether solenoid valve is normal.</li> <li>● Check whether pressure control parameters are set correctly.</li> </ul>
BIT11=1	Temperature alarm	<ul style="list-style-type: none"> <li>● Actual temperature detected by PT1 is higher than the alarm temperature set by P18.20.</li> </ul>	<ul style="list-style-type: none"> <li>● Check whether fan control parameters are correct.</li> <li>● Whether fan operates normally.</li> <li>● Fan power is too small to dissipate heat effectively.</li> <li>● Check whether there is lubricating oil.</li> </ul>
BIT12=1	Pressure signal fault	<ul style="list-style-type: none"> <li>● The actual voltage is detected by P1 to be less than 1V.</li> </ul>	<ul style="list-style-type: none"> <li>● Pressure detection sensor is abnormal.</li> <li>● Pressure detection input P1 signal wire is disconnected.</li> <li>● Pressure signal interface does</li> </ul>

P19.13	State type	Possible cause	Solution
			not select current signal.
BIT13=1	Temperature signal fault	<ul style="list-style-type: none"> <li>PT100 sensor is disconnected.</li> </ul>	<ul style="list-style-type: none"> <li>Check whether the wiring of PT100 is normal.</li> <li>Check whether temperature detection sensor is abnormal.</li> <li>Temperature detection input circuit is abnormal.</li> </ul>
BIT14=1	Low-temperature protection pre-alarm	<ul style="list-style-type: none"> <li>The actual temperature detected by PT1 is less than the low temperature protection threshold set by P18.21.</li> </ul>	<ul style="list-style-type: none"> <li>Temperature detection sensor is abnormal.</li> <li>Temperature detection input circuit is abnormal.</li> <li>Actual temperature is too low, and low temperature pre-alarm is reported accordingly, and therefore the air compressor cannot start.</li> </ul>

P19.14	State type	Possible cause	Solution
BIT0=1	Part 1 needs maintenance	<ul style="list-style-type: none"> <li>The running time of part 1 exceeds the time set by P19.00.</li> </ul>	<ul style="list-style-type: none"> <li>Carry out maintenance after stop</li> </ul>
BIT1=1	Part 2 needs maintenance	<ul style="list-style-type: none"> <li>The running time of part 2 exceeds the time set by P19.01.</li> </ul>	<ul style="list-style-type: none"> <li>Carry out maintenance after stop</li> </ul>
BIT2=1	Part 3 needs maintenance	<ul style="list-style-type: none"> <li>The running time of part 3 exceeds the time set by P19.02.</li> </ul>	<ul style="list-style-type: none"> <li>Carry out maintenance after stop</li> </ul>
BIT3=1	Part 4 needs maintenance	<ul style="list-style-type: none"> <li>The running time of part 4 exceeds the time set by P19.03.</li> </ul>	<ul style="list-style-type: none"> <li>Carry out maintenance after stop</li> </ul>
BIT4=1	Part 5 needs maintenance	<ul style="list-style-type: none"> <li>The running time of part 5 exceeds the time set by P19.04.</li> </ul>	<ul style="list-style-type: none"> <li>Carry out maintenance after stop</li> </ul>
BIT5=1	Auxiliary pressure signal fault	<ul style="list-style-type: none"> <li>The actual voltage detected by P2 is less than 1V.</li> </ul>	<ul style="list-style-type: none"> <li>Pressure detection sensor is abnormal.</li> <li>Pressure detection input P2 signal wire is disconnected.</li> </ul>
BIT6=1	Auxiliary temperature signal fault	<ul style="list-style-type: none"> <li>PT100 sensor is disconnected.</li> </ul>	<ul style="list-style-type: none"> <li>Check whether the wiring of PT100 is normal.</li> </ul>

P19.14	State type	Possible cause	Solution
			<ul style="list-style-type: none"> <li>● Temperature detection sensor is abnormal.</li> <li>● Temperature detection input circuit is abnormal.</li> </ul>
BIT7=1	Auxiliary pressure pre-alarm	<ul style="list-style-type: none"> <li>● The actual voltage detected by P2 is larger than the pre-alarm pressure set by P18.17</li> </ul>	<ul style="list-style-type: none"> <li>● Pressure detection sensor is abnormal.</li> <li>● The pressure is set to a too large value.</li> <li>● Adjust pressure PID regulator.</li> </ul>
BIT8=1	Auxiliary temperature pre-alarm	<ul style="list-style-type: none"> <li>● The actual temperature detected by PT2 is larger than the pre-alarm temperature set by P18.19</li> </ul>	<ul style="list-style-type: none"> <li>● Temperature detection sensor is abnormal.</li> <li>● Temperature detection input circuit is abnormal, if not calibrated.</li> <li>● The starting temperature of the fan is set to a too high value.</li> <li>● The temperature of the fan is set to a too high value.</li> <li>● Fan power is too small to dissipate heat effectively.</li> </ul>
BIT9=1	Auxiliary pressure alarm	<ul style="list-style-type: none"> <li>● The actual voltage detected by P2 is larger than the alarm pressure set by P18.18.</li> </ul>	<ul style="list-style-type: none"> <li>● Pressure detection sensor is abnormal.</li> <li>● The voltage is set to a too high value.</li> <li>● Adjust pressure PID regulator.</li> </ul>
BIT10=1	Auxiliary temperature alarm	<ul style="list-style-type: none"> <li>● The actual temperature detected by PT2 is higher than the alarm temperature set by P18.20.</li> </ul>	<ul style="list-style-type: none"> <li>● Temperature detection sensor is abnormal.</li> <li>● Temperature detection input circuit is abnormal, if not calibrated.</li> <li>● The starting temperature of the fan is set to a too high value.</li> <li>● The temperature of the fan is set to a too high value.</li> <li>● The fan power is too small to dissipate heat effectively.</li> </ul>

P19.14	State type	Possible cause	Solution
BIT11=1	Maintenance timeout alarm	<ul style="list-style-type: none"> <li>● Any part whose running time exceeds the set value will enter overtime maintenance stage, and hereafter, if the running time exceeds the time set by P18.45 again, maintenance timeout alarm will be reported.</li> </ul>	<ul style="list-style-type: none"> <li>● Carry out maintenance on the timeout parts after stop.</li> </ul>

## Appendix A Product dimension

### A.1 Keypad diagram

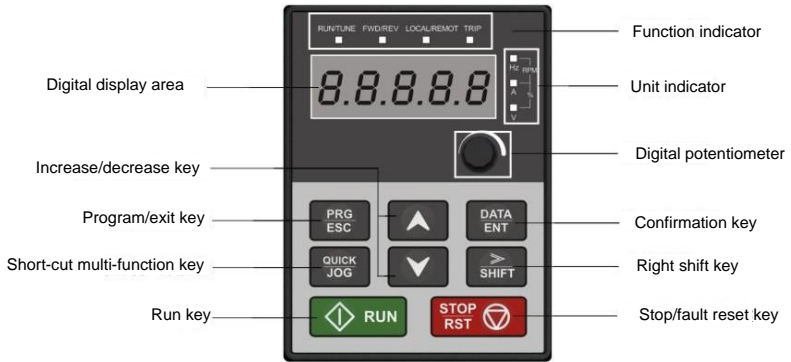

### A.2 External keypad installation dimensions

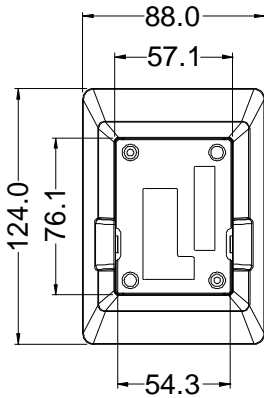

Simple keypad bracket  
(61006-00911)

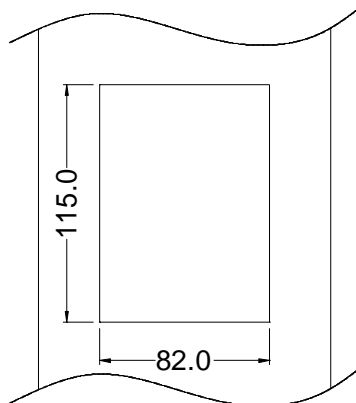

Customer installation  
dimensions

### A.3 Wall installation dimension

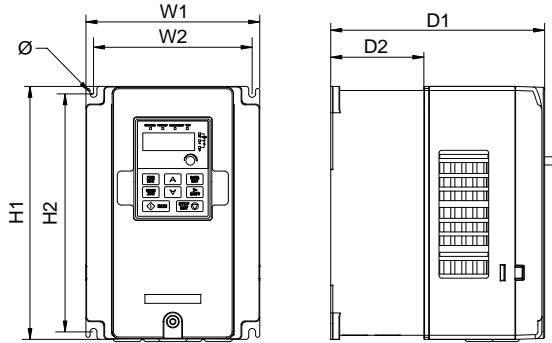

Figure A-1 7.5kW-37kW wall installation diagram

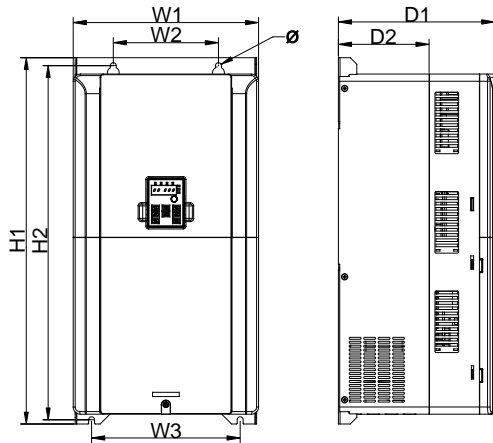

Figure A-2 45kW-55kW wall installation diagram

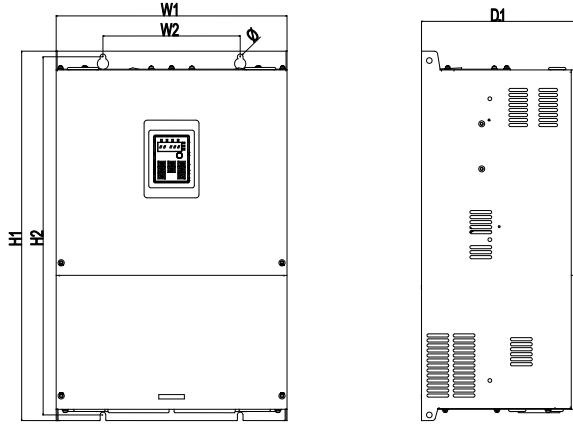

Figure A-3 75kW wall installation diagram

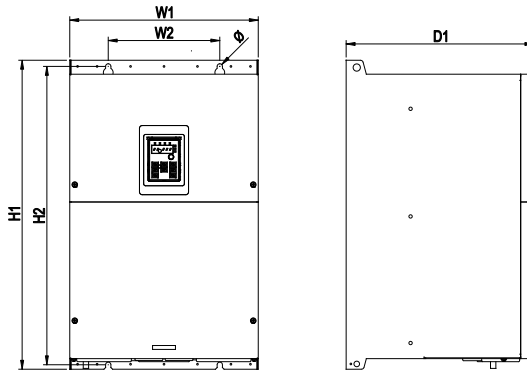

Figure A-4 90kW-110kW wall installation diagram

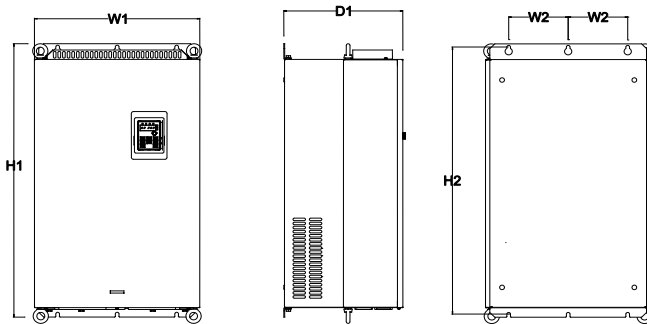

Figure A-5 132kW-200kW wall installation diagram

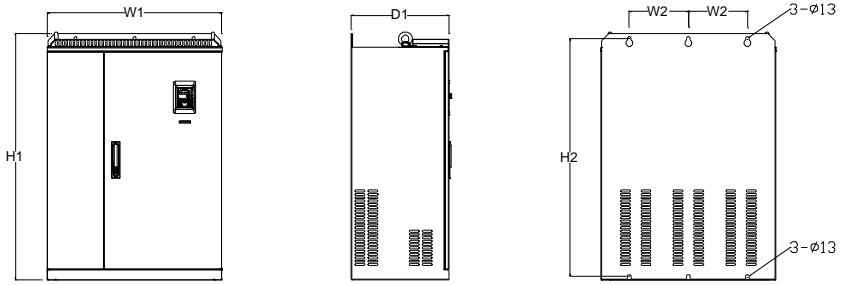

Figure A-6 220kW–315kW wall installation diagram

Table A-1 Wall installation dimension of 7.5kW–315kW single VFD (unit: mm)

Power	W1	W2	W3	H1	H2	D1	D2	Diameter of mounting hole
7.5kW	170	151	/	320	303.5	196.5	113	Ø 6
11kW–22kW	200	185	/	340.5	328.5	184.5	104.5	Ø 6
30kW–37kW	250	230	/	400	380	202	123.5	Ø 6
45kW–55kW	282	160	226.0	560	542	238	138	Ø 9
75kW	370	220	/	590	572	250	/	Ø 9
90kW–110kW	338	200	/	554	535	337	/	Ø 9.5
132kW–200kW	500	180	/	870	850	360	/	Ø 11
220kW–315kW	680	230	/	960	926	380	/	Ø 13

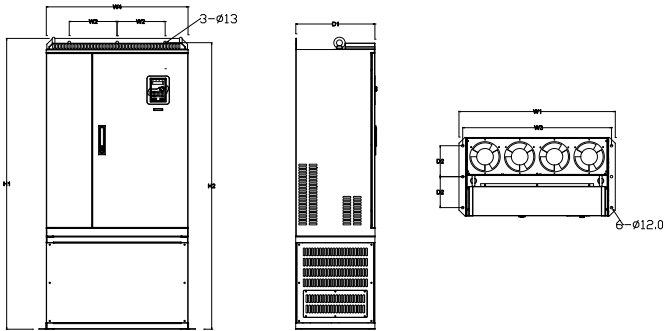

Figure A-7 220kW–315kW floor installation diagram

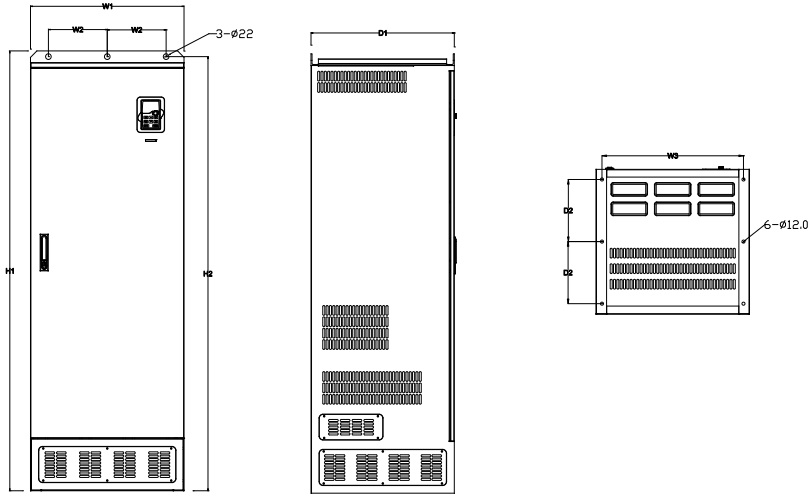

Figure A-8 350kW-500kW floor installation diagram

Table A-2 Floor installation dimension of 220kW-500kW single VFD (unit: mm)

Power	W1	W2	W3	W4	H1	H2	D1	D2	Diameter of mounting hole
220kW-315kW	750	230	714	680	1410	1390	380	150	Ø 13/12
350kW-500kW	620	230	573	/	1700	1678	560	240	Ø 22/12

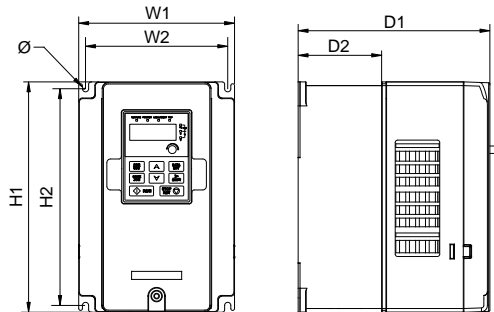

Figure A-9 Wall installation diagram of 7.5kW-15kW single VFD integrated machine

Table A-3 Wall installation dimension of 7.5kW-15kW single-VFD integrated machine (unit: mm)

Power	W1	W2	H1	H2	D1	D2	Diameter of mounting hole
7.5kW-15kW	200	185	340.5	328.5	184.5	104.5	Ø 6

### A.4 Flange installation dimension

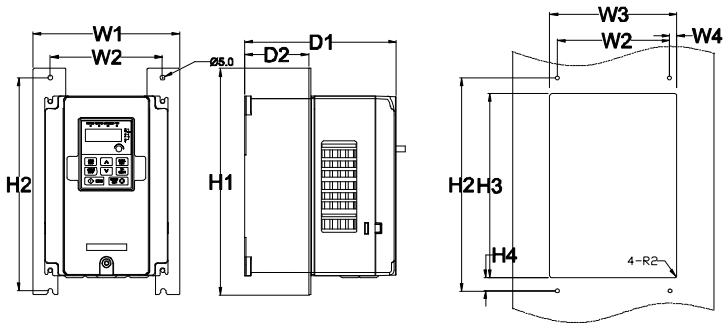

Figure A-10 7.5kW-55kW flange installation diagram

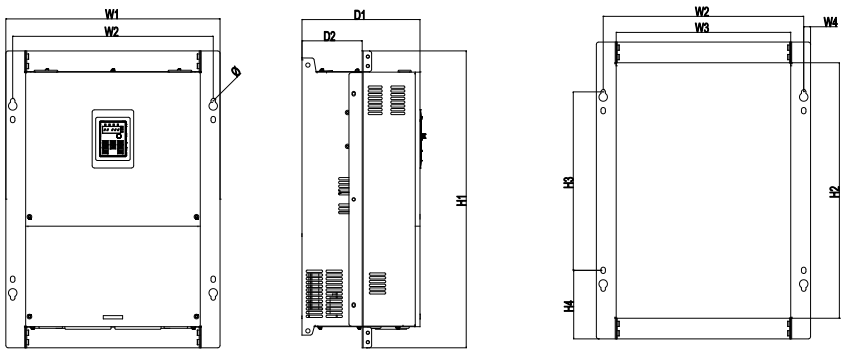

Figure A-11 75kW flange installation diagram

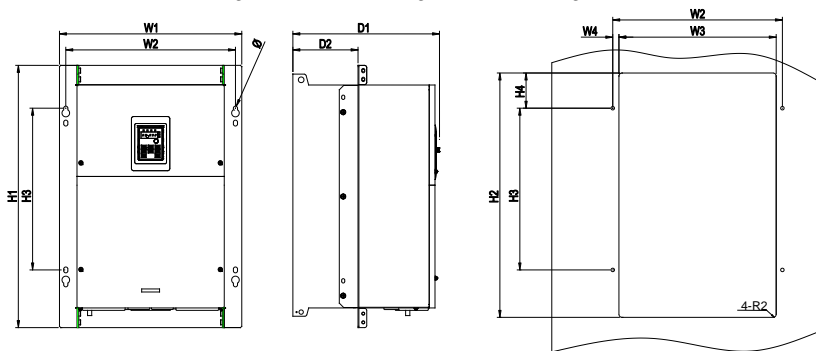

Figure A-12 90kW-110kW flange installation diagram

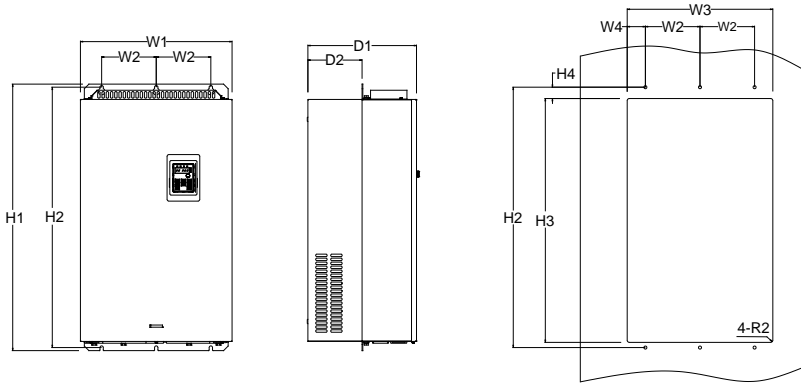

Figure A-13 132kW–200kW flange installation diagram

Table A-4 7.5kW–200kW flange installation dimension (unit: mm)

Power	W1	W2	W3	W4	H1	H2	H3	H4	D1	D2	Diameter of mounting hole	Nut specification
7.5kW	191	151	174	11.5	370	351	324	12	196.5	113	Ø 6	M5
11kW–22kW	266	250	224	13	371	250	350.5	20.5	184.5	104	Ø 6	M5
30kW–37kW	316	300	274	13	430	300	410	55	202	118.5	Ø 6	M5
45kW–55kW	352	332	306	13	580	400	570	80	238	134	Ø 9	M8
75kW	454	425	370	14.5	632	544	380	146	250	127.5	Ø 9.5	M8
90kW–110kW	418	389	361	14	600	559	370	80	337	150	Ø 9.5	M8
132kW–200kW	500	180	480	60	870	850	796	37	358	178.5	Ø 11	M12

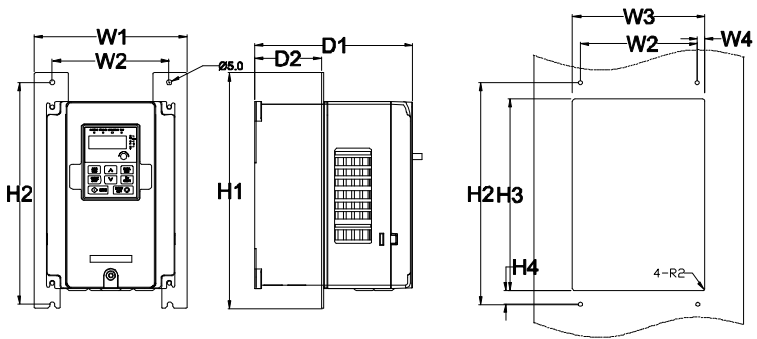

Figure A-14 Flange installation diagram of 7.5kW–15kW single-VFD integrated machine

Table A-5 Flange installation dimension of 7.5kW–15kW single-VFD integrated machine (mm)

Power	W1	W2	W3	W4	H1	H2	H3	H4	D1	D2	Diameter of mounting hole	Nut specification
7.5kW–15kW	266	250	224	13	371	250	350.5	20.5	184.5	104	Ø 6	M5

**Note:** Flange mounting plates are often required for flange installation. For 132–200kW models, you can move the upper and lower mounting beams to the middle position but not use flange mounting plates. Floor installation but not flange installation is recommended for 220kW and higher models.

## A.5 Product weight and package dimension

### A.5.1 Weight and package dimension of single-VFD product

Product model	N/W (kg)	G/W (kg)	Package dimension (mm)
GD300-01A-7R5G-4	5.6	6.6	428x270x328
GD300-01A-011G-4	6.6	8.2	485x325x320
GD300-01A-015G-4	8.7	10.3	485x325x320
GD300-01A-018G-4	10.4	12.0	485x325x320
GD300-01A-022G-4	10.4	12.0	485x325x320
GD300-01A-030G-4	16.0	18.5	580x395x360
GD300-01A-037G-4	16.0	18.5	580x395x360
GD300-01A-045G-4	37.0	48.0	710x510x495
GD300-01A-055G-4	37.0	48.0	710x510x495
GD300-01A-075G-4	37.0	48.0	710x510x495
GD300-01A-090G-4	45.5	56.5	675x470x575
GD300-01A-110G-4	46.5	57.5	675x470x575
GD300-01A-132G-4	76.0	97.0	971x631x565
GD300-01A-160G-4	76.0	97.0	971x631x565
GD300-01A-185G-4	76.0	97.0	971x631x565
GD300-01A-200G-4	76.0	97.0	971x631x565
GD300-01A-220G-4	135	165	1086x826x595
GD300-01A-250G-4	135	165	1086x826x595
GD300-01A-280G-4	135	165	1086x826x595
GD300-01A-315G-4	137	167	1086x826x595
GD300-01A-350G-4	410	450	1850x840x820
GD300-01A-400G-4	410	450	1850x840x820
GD300-01A-500G-4	410	450	1850x840x820

### A.5.2 Weight and package dimension of single-VFD integrated machine

Product model	N/W (kg)	G/W (kg)	Package dimension (mm)
GD300-01A-7R5G-4-CT	6.6	8.2	485x325x320
GD300-01A-011G-4-CT	6.6	8.2	485x325x320
GD300-01A-015G-4-CT	8.7	10.3	485x325x320

## Appendix B External optional accessories

### B.1 RS485 LCD keypad

#### B.1.1 LCD keypad introduction

GD300-01A series VFD supports the use of the optional LCD keypad that uses RS485 communication. The LCD keypad can be used to control the start and stop of the VFD, read and write the status data, and set the parameters.

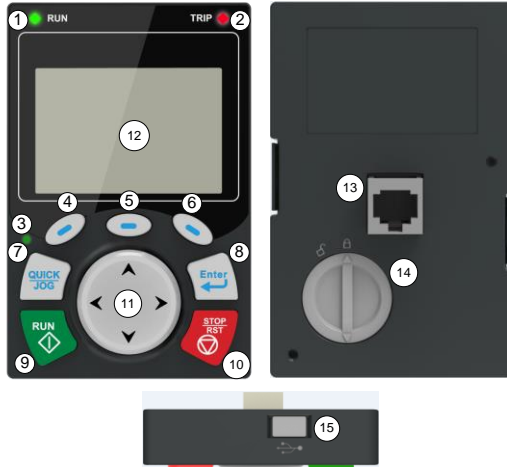

Figure B-1 LCD keypad

**Note:**









- ✧ The LCD keypad has a real-time clock for display. After battery installation, the clock can work properly even after power failure. You need to purchase the battery (model CR2032) by yourself.
- ✧ The LCD keypad has the parameter copying function.
- ✧ When you externally connect the keypad to the VFD, use M3 screws to secure the keypad or use the optional keypad bracket to install the keypad. In addition, you need to use the keypad extension cable with the standard RJ45 crystal head.







Table B-1 Ordering description for the RS485 LCD keypad

Item	Description	Order No.
RS485 LCD keypad	Includes a 2.5-meter RS485 keypad cable, a 2.5-meter emergency stop cable, and an installation bracket.	11022-00141

Table B-2 LCD keypad description

Item	Description		
Status indicator	①		VFD running status indicator. LED on: in running state

Item	Description			
			LED off: in stopped state LED blinking: in parameter autotuning state	
	②		Fault indicator. LED on: in fault state LED off: in normal state LED blinking: in pre-alarm state	
	③		Shortcut key indicator, which displays different states under different functions. See the definition of <b>QUICK/JOG</b> for details.	
Keys	④		Function key	The function of a function key varies with the menu and is displayed at the bottom of the display area.
	⑤			
	⑥			
	⑦		Shortcut key	Re-definable. It is defined as <b>JOG</b> function by default, namely jogging. The function of the shortcut key can be set through the ones place of P07.02: 0: No function 1: Jog (linked with indicator ③, logic: steady on) 2: Switch display status using the shifting key 3: Switch between FWD/REV running (linked with indicator ③, logic: steady off) 4: Clear the <b>UP/DOWN</b> setting (linked with indicator ③, logic: steady off) 5: Coast to stop (linked with indicator ③, logic: steady off) 6: Switch running-command giving modes in order (linked with indicator ③, logic: steady off) 7: Quick debugging mode (non factory parameter debugging) Note: After restoring to the default setting, the default function of the shortcut key is 1.
	⑧		Confirmation key	The confirmation key function varies with the menu (Example: confirming parameter settings, confirming parameter selection, and entering the next menu)
⑨		Run key	Under keypad operation mode, the run key is used for running or autotuning.	

Item	Description			
	⑩		<p>Stop/Reset key</p>	<p>In running state, you can press this key to stop running or autotuning. This key is restricted by P07.04. In fault alarm state, this key can be used for reset in any control modes.</p>
	⑪		<p>Direction key                      Up:                       Down:                       Left:                       Right: </p>	<p>Up: Its function varies with the interface (Example: shifting up the displayed/selected item and changing digits)                      Down: Its function varies with the interface (Example: shifting down the displayed/selected item and changing digits)                      Left: Its function varies with the interface (Example: switching the monitoring interface)                      Right: Its function varies with the interface (Example: switching the monitoring interface)</p>
Display area	⑫	LCD	Display screen	240*160 dot-matrix LCD, able to display three monitoring parameters or six sub-menu items simultaneously.
Other	⑬	RJ45 interface	RJ45 interface	The RJ45 interface is used to connect to the VFD.
	⑭	Battery cover	Clock battery cover	To replace or mount the clock battery, remove this cover, and then close the cover after the battery is mounted.
	⑮	USB terminal	Mini USB terminal	The mini USB terminal is used to connect to the USB flash drive through an adapter.

**B.1.2 LCD keypad structure**

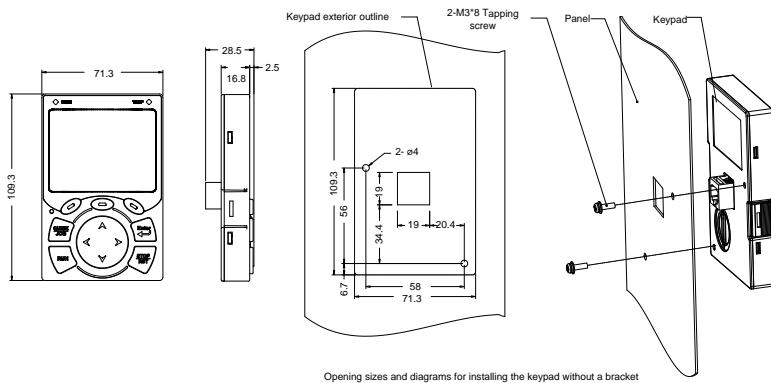

Figure B-2 LCD keypad structure diagram

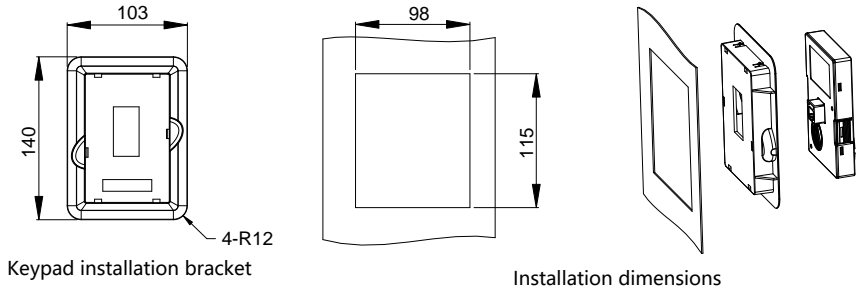

Figure B-3 Keypad installation bracket

**B.1.3 RS485 communication cable**

**B.1.3.1 Connection description**

Please use the provided RS485 communication cable, of which one end is connected to the keypad network port and the other is connected to the CN7 terminal of the VFD control board.

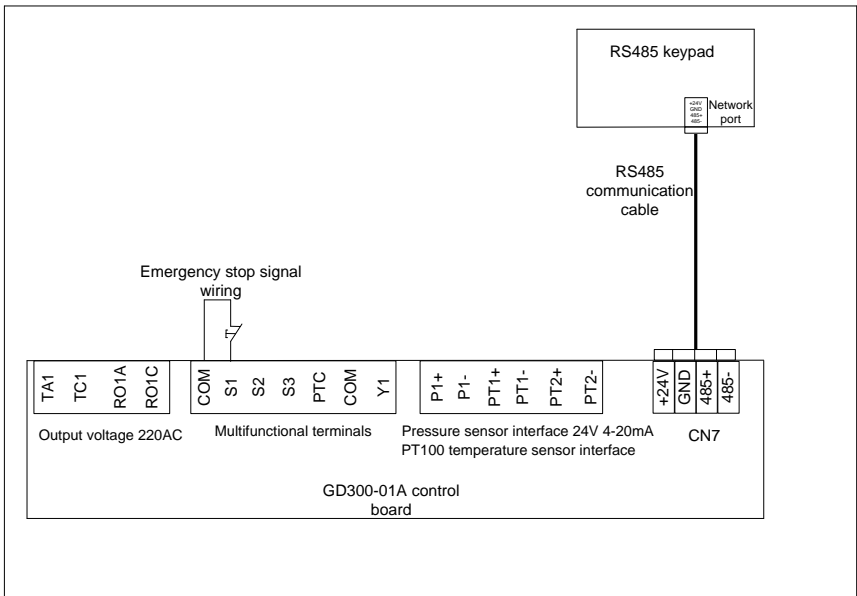

Figure B-4 RS485 communication cable connection diagram

**B.1.3.2 Cable description**

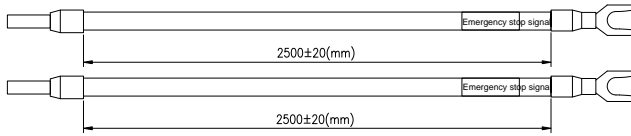

Figure B-5 Emergency stop cable diagram

**Note:** The emergency stop cable is used for emergency stop control when a device fault occurs and it is often connected to the S1 terminal and COM terminal.

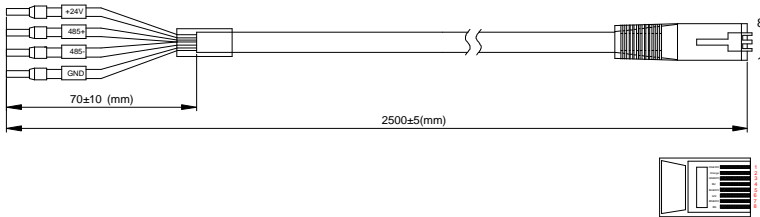

Figure B-6 RS485 communication cable diagram

Table B-3 Wires and terminals

Network port diagram	Terminal	Wire		
	GND	Orange&white	1	Twisted pair
		Orange	2	
	485-	Green&white	3	3 and 6 twisted pair
		Blue	4	
	485+	Blue&white	5	4 and 5 twisted pair
		Green	6	
	+24V	Brown&white	7	Twisted pair
		Brown	8	

**B.1.4 Setting parameters on the LCD keypad**

**B.1.4.1 Initial interface**

After power-on and startup, the initial interface appears, as shown in Figure B-7. The LCD keypad displays the product name and software version on this interface and goes to the working environment interface three seconds later.

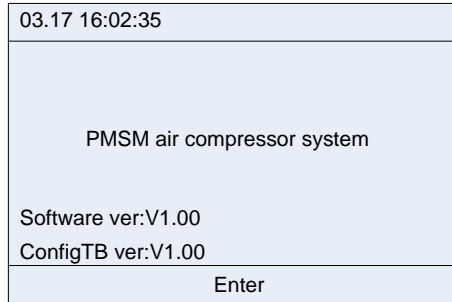

Figure B-7 Initial interface

**B.1.4.2 Working environment interface**

The working environment interface displays certain parameters about the running.

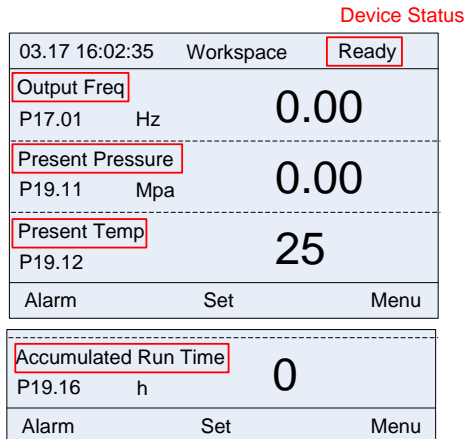

Figure B-8 Working environment

Parameter	Description
Device status	Ready: indicates the device is not started and it does not encounter an alarm. Only when the device is in standby state, the device can be started and the device startup key is valid.
	Run: indicates that the device is started and does not encounter an alarm.
	Fault: indicates that the master VFD or fan VFD encounters a fault. The fault alarm is cleared only after the fault is handled.
	Emergency stop: indicates that the emergency stop key is pressed. It is cleared only after the emergency stop key is reset.
	Undervoltage: indicates that the master VFD bus voltage is too low. In this case, you need to check the input power supply.

Parameter	Description
	<p>Alarm: The alarm type is displayed in the pre-alarm area.                      When the temperature reaches the alarm threshold, the alarm is reported and the device stops.                      When the temperature reaches the pre-alarm threshold, the temperature is displayed in the pre-alarm area but the device continues running.                      When the temperature is lower than the low temperature protection threshold, the alarm is reported, low temperature protection is displayed, and the device stops running.                      When the pressure reaches the alarm threshold, the alarm is reported and the device stops.                      When the pressure reaches the pre-alarm threshold, the pre-alarm is displayed in the pre-alarm area, but the device continues running.</p> <p>Sleep: When you choose the sleep function and the master empty-load running time reaches the sleep time that is set, the device enters the sleep state. The device automatically wakes up when the pressure is lower than the loading pressure.</p> <p>Stop: indicates that the device has stopped.</p> <p>Restart delay: is used for device protection. If you press the restart key immediately after pressing the stop key, the device can be restarted with a restart delay, which is displayed and counted down. When the countdown time is 0, the device enters the standby state, and the start key is valid.</p> <p>Off: indicates the RS485 communication between the LCD keypad and VFD is disconnected.</p>
Output frequency	It displays the value of the current running frequency of the master VFD.
Present pressure	It displays the value of the current pressure.
Present temperature	It displays the value of the current temperature.
Accumulated run time	It displays the total running time of device.

**B.1.4.3 Setting interface**

In the main interface, you can press  **Set** to enter the following interface:

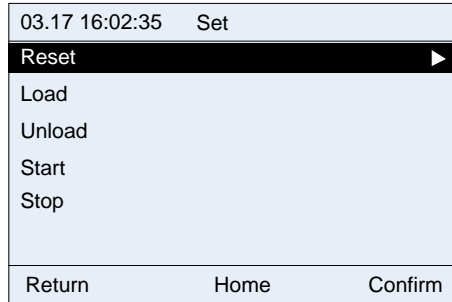

Figure B-9 Setting interface

In this interface, you can press the Up or Down key to select different operation functions. Then press



**OK** for control; press



**Back** or



**Home** to return to the working environment interface.

- **Reset:** enables you to reset a fault that the master VFD or fan VFD encounters.
- **Load/Unload:** controls the start or stop of the intake valve in manual loading or unloading mode.
- **Start:** enables you to start the device. The device can be started only in standby state.
- **Stop:** enables you to stop the device.

**Note:** You can implement the start, stop, and reset functions by pressing the **RUN** and **STOP/RST** keys on the keypad.

#### B.1.4.4 Alarm interface



You can press **Alarm** in the main interface to access real-time alarm interface and view all the alarm records since the device power-on.

**Note:** This function equals the shortcut to **Menu > Fault records > Real-time alarm**. The only difference is that a real-time alarm that is accessed by using this shortcut method cannot be cleared in this interface and it can be cleared only in the fault record interface.

03.17 16:02:35 Real-time alarm	
000. 03-17 16:00:05 xxx fault	
001. 03-17 15:49:30 xxx fault	
002. 03-17 15:08:20 xxx fault	
...	
Return	Home

Figure B-10 Real-time alarm interface

**B.1.4.5 Main menu interface**

In the main interface, you can press  **Menu** to enter the main menu interface, which contains user parameters, maintenance parameters, protection parameters, running information, master parameters, fan parameters, fault records, VFD information, and system configuration. You can press

the **Up** or **Down** key to switch between the menu items and then press  **Select** to enter a specific menu item.

03.17 16:02:35 Menu		
User param ▶		
Maintain param		
Protection param		
Run information		
Master param		
Fan param		
Return	Home	Select
Fault records		
VFD information		
System config ▶		
Return	Home	Select

Figure B-11 Main menu interface

**B.1.4.6 User parameter interface**

1. Enter the user parameter interface through the main menu.

03.17 16:02:35 User param		
Set pressure	xxx.xx Mpa	▶
Unloading pressure	xxx.xx Mpa	
Loading pressure	xxx.xx Mpa	
Setting Temp	xxxxxx	
Fan Starting Temp	xxxxxx	
Fan Stopping Temp	xxxxxx	
Return	Home	Edit

03.17 16:02:35 User param		
Loading Delay	xxxxxx s	
Stop Delay	xxxxxx s	
No-load Delay	xxxxxx s	
Restart Delay	xxxxxx s	
Sleep Function	Enable	
Load/Unload Mode	Automatic	▶
Return	Home	Edit

03.17 16:02:35 User param		
Restart Delay	xxxxxx s	
Sleep Function	Enable	
Load/Unload Mode	Automatic	
Power consumption	xxxx.x kW.h	
Accumlated Run Time	xxxxxx h	
Timing switch setting		▶
Return	Home	Edit

Figure B-12 User parameter interface

User parameter	Initial value	Function
Set temperature	75°C	Constant exhaust temperature that is set for constant temperature control on fan.
Fan stop temperature	65°C	When the exhaust temperature is lower than this value, the fan is stopped.
Fan startup temperature	75°C	When the exhaust temperature is higher than this value, the fan is started.

User parameter	Initial value	Function
Loading delay	10S	After the startup, the air compressor runs with load with this specified delay.
Load/unload mode	Automatic	If the manual mode is used, both load and unload need to be manually performed after the air compressor is started. If the automatic mode is used, the air compressor automatically loads or unloads depending on the pressure after being started.
Sleep function	Enable	Disable/Enable
No-load delay	300S	Max. continuous empty-load running time allowed by the air compressor. If the time is reached, the air compressor enters the sleep state.
Stop delay	0S	Before stop, the device runs at the empty-load frequency and stops with this specified delay.
Restart delay	30s	After the device stops, the device determines whether to start with this specified delay.
Set pressure	0.70 MPa	Air supply pressure during stable running. The VFD controls the running frequency according to this pressure so as to implement constant pressure for air supply.
Unloading pressure	0.80 MPa	If the pressure is higher than this value when the air compressor is running, the VFD controls the air compressor to run without load.
Loading pressure	0.60 MPa	If the VFD detects the pressure is lower than this value when the air compressor is running without load, the VFD controls the air compressor to run with load. If the VFD detects the pressure is lower than this value when the air compressor is sleeping, the master is waken up.
Power consumption	/	All the electricity consumption (kWh) of the VFD system. The value is automatically generated and cannot be set, but it can be cleared.
Accumulated run time	/	Accumulative running time (hours) of the VFD system. The value is automatically generated and cannot be set, but it can be cleared.
Timing switch setting		Press Set to access the corresponding interface. Startup time: Scheduled time when the device is automatically started. Shutdown time: Scheduled time when the device is automatically stopped. Startup action: Disable/enable (Timed startup is valid only in Enabled state. Otherwise, the device is not automatically

User parameter	Initial value	Function
		started even though the scheduled startup time has been set.) Shutdown action: Disable/enable (Timed stop is valid only in Enabled state. Otherwise, the device is not automatically stopped even though the scheduled shutdown time has been set.)

2. In the user parameter interface, you can edit parameters only after entering the correct user password.

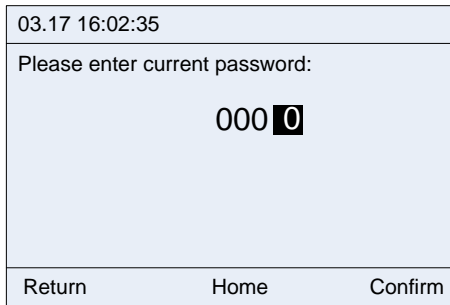

Figure B-13 User password input interface

3. Set user parameters after entering the correct user password.

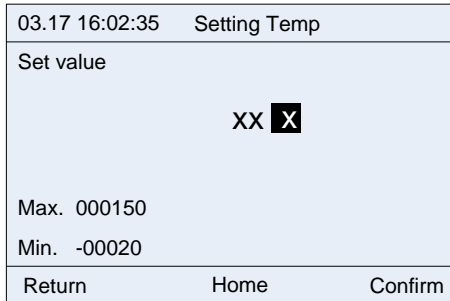

Figure B-14 Temperature setting interface

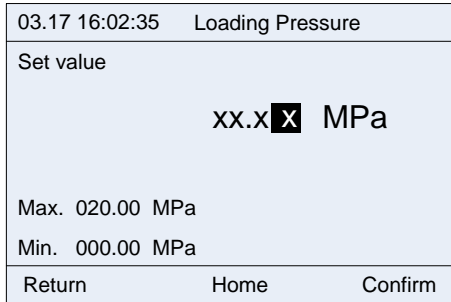

Figure B-15 Loading pressure setting interface

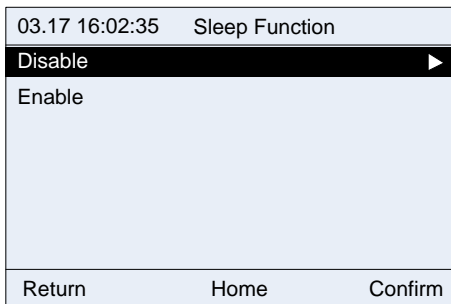

Figure B-16 Sleep function selection interface

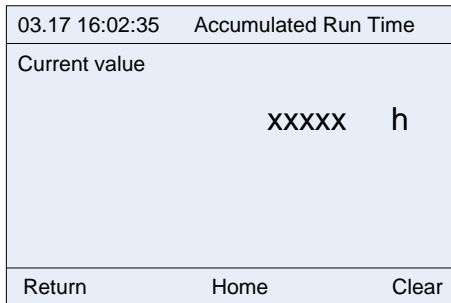

Figure B-17 Accumulative running time display interface

In the **Timing switch setting** (timed startup/stop setting) interface, you can control the VFD to start or stop in different time points each day. To be specific, you can set a maximum of five scheduled startup/stop time points each day from Monday to Sunday.

03.17 16:02:35 Timing switch setting		
Mon. ▶		
Tues.		
Wed.		
Thurs.		
Fri.		
Sat.		
Return	Home	Select

Figure B-18 Date selection interface

03.17 16:02:35 Mon.			
Boot time	ShutTime	Boot	Shutdown ▶
0 0:0 0	0 0:0 0	Disable	Disable
0 0:0 0	0 0:0 0	Disable	Disable
0 0:0 0	0 0:0 0	Disable	Disable
0 0:0 0	0 0:0 0	Disable	Disable
0 0:0 0	0 0:0 0	Disable	Disable
Return	Home	Edit	

Figure B-19 Start/stop action selection interface

03.17 16:02:35 Mon.			
Boot time	ShutTime	Boot	Shutdown
0 0:0 0	0 0:0 0	Disable	Disable
Return	Home	Confirm	

Figure B-20 Start/stop status setting interface

**B.1.4.7 Maintenance parameter interface**

1. Enter the maintenance parameter interface through the main menu.

03.17 16:02:35 Maintain param		
Air filter set time	xxxxxx h	▶
Oil filter set time	xxxxxx h	
Splitter set time	xxxxxx h	
Lubricat Oil set time	xxxxxx h	
Grease set time	xxxxxx h	
Air filter run time	xxxxxx h	
Return	Home	Edit

03.17 16:02:35 Maintain param		
Grease set time	xxxxxx h	
Air filter run time	xxxxxx h	
Oil filter run time	xxxxxx h	
Splitter run time	xxxxxx h	
Lubricat Oil run time	xxxxxx h	
Grease run time	xxxxxx h	▶
Return	Home	Edit

Figure B-21 Maintenance parameter interface

Maintenance parameter	Initial value	Function
Air filter set time	0	If the accumulative air filter use time exceeds this value, a pre-alarm is displayed. If this value is set to 0, no pre-alarm is displayed.
Oil filter set time	0	If the accumulative oil filter use time exceeds this value, a pre-alarm is displayed. If this value is set to 0, no pre-alarm is displayed.
Splitter set time	0	If the accumulative splitter use time exceeds this value, a pre-alarm is displayed. If this value is set to 0, no pre-alarm is displayed.
Lubricate oil set time	0	If the accumulative lubrication oil use time exceeds this value, a pre-alarm is displayed. If this value is set to 0, no pre-alarm is displayed.
Grease set time	0	If the accumulative grease use time exceeds this value, a pre-alarm is displayed. If this value is set to 0, no pre-alarm is displayed.

Maintenance parameter	Initial value	Function
Air filter run time	/	It is cleared when a new air filter is used.
Oil filter run time	/	It is cleared when a new oil filter is used.
Splitter run time	/	It is cleared when a new splitter is used.
Lubricate oil run time	/	It is cleared when new lubrication oil is used.
Grease run time	/	It is cleared when new grease is used.

2. You can edit parameters after entering the correct administrator password.

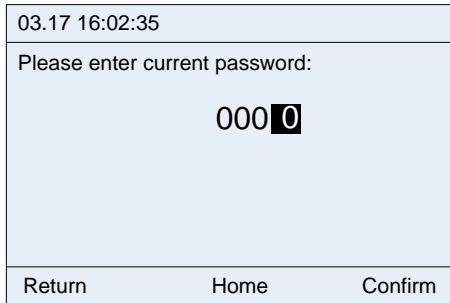

Figure B-22 Administrator password input interface

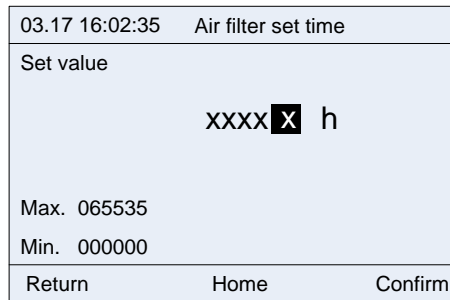

Figure B-23 Air filter set time

Maintenance parameters are set according to the use status of accessories. During running, if the use time of an accessory is equal to or greater than the set time, a pre-alarm is displayed, indicating that the accessory needs maintenance or it needs to be replaced. The use time needs to be cleared to 0 when the new accessory is used.

03.17 16:02:35	Oil filter run time
Current value	
XXXXXX h	
Return	Home Clear

Figure B-24 Accumulative oil filter use time

**B.1.4.8 Protection parameter interface**

1. Enter the protection parameter interface through the main menu.

03.17 16:02:35	Protection param
<b>Prealarm Pressure</b>	<b>xxx.xx MPa ▶</b>
Alarm Pressure	xxx.xx Mpa
Prealarm Temp	xxxxxx
Alarm Temp	xxxxxx
Low Temp Protect Thred	xxxxxx
Auxiliary Press Protection	Invalid
Return	Home Edit

03.17 16:02:35	Protection param
Auxiliary Press Prealarm	xxx.xx MPa
Auxiliary Press Alarm	xxx.xx MPa
Auxiliary Temp Proteciton	Invalid
Present Auxiliary Temp	xxxxxx
Auxiliary Temp Prealarm	xxxxxx
<b>Auxiliary Temp Alarm</b>	<b>xxxxxx ▶</b>
Return	Home Edit

Figure B-25 Protection parameter interface

Protection parameter	Initial value	Function
Prealarm temperature	105°C	When the actual exhaust temperature is higher than this temperature, a pre-alarm is reported.
Alarm temperature	110°C	When the actual exhaust temperature is higher than this temperature, an alarm is reported, and the device is stopped.

Protection parameter	Initial value	Function
Prealarm pressure	0.90Mpa	When the actual air supply pressure is higher than this pressure, a pre-alarm is reported.
Alarm pressure	1.00Mpa	When the actual air supply pressure is higher than this pressure, an alarm is reported, and the device is stopped.
Auxiliary temperature prealarm	105°C	When the detected temperature is higher than this temperature, a pre-alarm is reported. This parameter is valid only after it is enabled in system configuration.
Auxiliary temperature alarm	110°C	When the detected temperature is higher than this temperature, an alarm is reported, and the device is stopped. This parameter is valid only after it is enabled in system configuration.
Auxiliary pressure prealarm	0.90Mpa	When the detected pressure is higher than this pressure, a pre-alarm is reported. This parameter is valid only after it is enabled in system configuration.
Alarm auxiliary pressure	1.00Mpa	When the detected pressure is higher than this pressure, an alarm is reported. This parameter is valid only after it is enabled in system configuration.
Low temperature protection threshold	-10°C	When the detected temperature is lower than this temperature, a low temperature pre-alarm is reported. This parameter is valid only after it is enabled in system configuration.
Current auxiliary temperature	/	It displays the auxiliary temperature that is currently detected.
Current auxiliary pressure	/	It displays the auxiliary pressure that is currently detected.
Enable auxiliary temperature protection	Disable	Disable/Enable
Enable auxiliary pressure protection	Disable	Disable/Enable

2. You can edit parameters only after entering the correct administrator password.

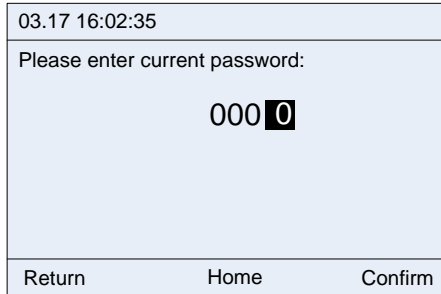

Figure B-26 Administrator password input interface

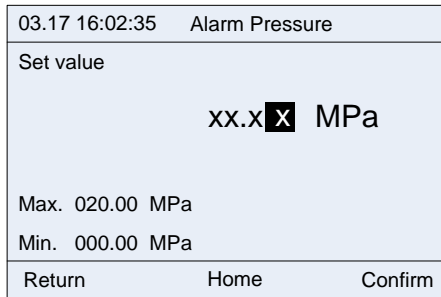

Figure B-27 Alarm pressure parameter setting interface

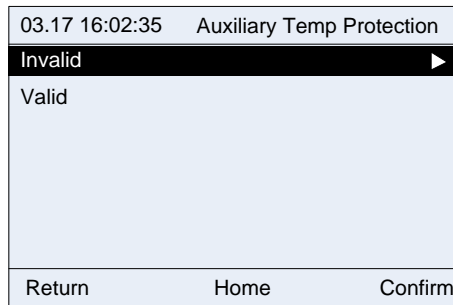

Figure B-28 Auxiliary temperature protection enabling

**B.1.4.9 Running information**

1. Enter the running information interface through the main menu. Running information includes master running information and fan running information.

03.17 16:02:35 Run information		
Master ▶		
Fan		
Return	Home	Select

Figure B-29 Running information interface

03.17 16:02:35 Master running info		
Output Current	xxxx.x A	▶
Output Voltage	xxxxxx V	
Motor Speed	xxxxxx rpm	
Output Freq	xxx.xx Hz	
Motor Actual Output Power	xxxx.x kW	
Present Pressure	xxx.xx MPa	
Return	Home	

Figure B-30 Master running information

03.17 16:02:35 Fan running info		
Fan State	Stop	▶
Temperature	xxxxxx	
Fan Phase A Display Current	xxxx.x A	
Fan Phase B Display Current	xxxx.x A	
Fan Phase C Display Current	xxxx.x A	
Return	Home	

Figure B-31 Fan running information

**Note:** Master and fan running information is read only and therefore cannot be edited.

**B.1.4.10 Master parameter interface**

1. Enter the master parameter interface through the main menu.

03.17 16:02:35 Master Param		
Max Ouput Freq	xxx.xx Hz	▶
Run Freq Up limit	xxx.xx Hz	
Run Freq Down limit	xxx.xx Hz	
Load Run Low Limit Freq	xxx.xx Hz	
No-load Run Freq	xxx.xx Hz	
Acc time	xxxx.x s	
Return	Home	Edit

03.17 16:02:35 Master param		
Sample Cycle	xx.xxx s	
Prop Gain	xxx.xx	
Integral Time	xxx.xx s	
Differential Time	xxx.xx s	
PID Output Uplimit	xxxx.x %	
PID Output Downlimit	xxxx.x %	▶
Return	Home	Edit

Figure B-32 Master parameter interface

Master parameter	Initial value	Function
Proportional gain (Kp)	10.00	It indicates the speed of tracking the set working pressure. A greater value indicates a higher speed of tracking and easier oscillation. A smaller value indicates a lower speed of tracking and slower adjustment. The recommended setting range is 5.00–15.00.
Integral time	2.00	The recommended setting range is 2.00–4.00.
Differential time (Td)	1.00	It is used for lag tracking on the large-scale lag system (such as temperature).
Sampling time (T)	0.100s	It indicates the sampling period for feedback values.
PID output upper limit	100%	It indicates the upper limit of the output of the PID regulator.
PID output lower limit	0.0%	It indicates the lower limit of the output of the PID regulator. It is set based on the lower limit frequency.
Max. output frequency	50.00Hz	It indicates the maximum output frequency of the VFD.

Master parameter	Initial value	Function
Running frequency upper limit	50.00Hz	It indicates the upper limit of the output frequency of the VFD.
Running frequency lower limit	00.00Hz	It indicates the lower limit of the output frequency of the VFD.
Loaded running frequency lower limit	40.00Hz	It indicates the minimum working frequency that is allowed to output when the pressure exceeds the set value but does not reach the unloading pressure during regulation.
Empty-load running frequency	38.00Hz	It indicates the working frequency when the air compressor is empty loaded.
ACC time	Model depended	It indicates the time taken by the VFD to accelerate from 0Hz to the maximum frequency.
DEC time	Model depended	It indicates the time taken by the VFD to decelerate from the maximum frequency to 0Hz.

2. You can edit parameters only after entering a correct administrator password.

03.17 16:02:35		
Please enter current password:		
000 <input type="password"/>		
Return	Home	Confirm

Figure B-33 Administrator password input interface

03.17 16:02:35	Max Output Freq	
Set value		
xxx.x <input type="text"/> Hz		
Max. 600.00 MPa		
Min. 000.00 MPa		
Return	Home	Confirm

Figure B-34 Maximum output frequency setting interface

03.17 16:02:35	Differential time	
Set value		
XX.XX S		
Max. 010.00 s		
Min. 000.00 s		
Return	Home	Confirm

Figure B-35 Differential time setting interface

**B.1.4.11 Fan parameter interface**

1. Enter the fan parameter interface through the main menu.

03.17 16:02:35	Fan param	
Rated Fan Current	xxxx.x A	▶
Fan Current Transfor Ratio xxx.x		
Current Imbalance Coeffi xxx.xx		
Phase A Cur Calib Coeffi xxx.x %		
Phase B Cur Calib Coeffi xxx.x %		
Phase C Cur Calib Coeffi xxx.x %		
Return	Home	Edit

Figure B-36 Fan parameter interface

Fan parameter	Initial value	Function
Rated fan current	0.0A	It is associated with the power-frequency fan current detection and overload protection functions. It is valid only when the value is not 0, and it is invalid when the value is 0. Setting range: 0–40.0
Fan current transfer ratio	1000.0	Setting range: 1.0–4000.0
Current imbalance coefficient	1.60	When ratio of the maximum current to the minimum current among the fan three-phase currents is greater than this value, the VFD reports the fan current unbalance fault. Setting range: 1.00–3.00
Phase A current calibration coefficient	100.0%	Actual current = Displayed current * Current coefficient factor

Fan parameter	Initial value	Function
Phase B current calibration coefficient		Setting range: 0.0–150.0% Note: When parameters are restored to the factory settings, this value is remained.
Phase C current calibration coefficient		

2. You can edit parameters only after entering a correct administrator password.

03.17 16:02:35		
Please enter current password:		
000 <input type="password"/>		
Return	Home	Confirm

Figure B-37 Administrator password input interface

03.17 16:02:35	Rated Fan Current
Set value	
xx. <input type="text"/> A	
Max. 0040.0 A	
Min. 0000.0 A	
Return	Home
Confirm	

Figure B-38 Fan rated current setting interface

03.17 16:02:35	Phase A Cur Calib Coeffi
Set value	
xxx. <input type="text"/> %	
Max. 0150.0 %	
Min. 0000.0 %	
Return	Home
Confirm	

Figure B-39 Fan A-phase current correction factor setting interface

**B.1.5 Fault records**

The fault record interface is used to display the fault and alarm information about current device running. If an alarm is reported, alarm information is displayed. Fault records include VFD faults, air compressor faults, real-time alarms, and historic alarms.

03.17 16:02:35 Fault records		
VFD fault ▶		
AirCompressor fault		
Real-time alarm		
Historical alarm		
Return	Home	Select

Figure B-40 Fault record interface

**B.1.5.1 VFD fault interface**

This interface displays fault information about the VFD. You can view the current fault and last five faults.

03.17 16:02:35 VFD fault		
Type of Current Fault	000019	▶
Type of Last Fault	0000xx	
Type of 2 <sup>nd</sup> Last Fault	0000xx	
Type of 3 <sup>rd</sup> Last Fault	0000xx	
Type of 4 <sup>th</sup> Last Fault	0000xx	
Type of 5 <sup>th</sup> Last Fault	0000xx	
Return	Home	Select

03.17 16:02:35 VFD fault	
Type of Current Fault:	
Current detection fault(ItE)	
Return	Home

Figure B-41 VFD fault interface

**B.1.5.2 Air compressor fault interface**

This interface displays air compressor exception information, including the air filter, oil filter, and separator blockage, maintenance need, and auxiliary pressure or temperature pre-alarm or alarm.

03.17 16:02:35 Air Compressor fault	
000. Oil filter jam signal fault	
001. External Signal 1 fault	
002. Pressure Prealarm	
003. Pressure Signal fault	
004. Maintenance timeout	
...	
Return	Home

Figure B-42 Air compressor fault interface

**B.1.5.3 Real-time alarm interface**

This interface displays all fault records including fault time in real time since the keypad is started. If the keypad is re-powered on, the real-time alarm records are cleared but these records have been saved in the history alarm records before the power-off.

When there are many real-time alarm records, you can use the Up and Down keys to shift.

In the working environment interface, the  **Alarm** key is the shortcut access to real-time alarms, but alarm information can be cleared only in this interface.

03.17 16:02:35 Real-time alarm		
000. 03-17 16:00:05 xxx fault		
001. 03-17 15:49:30 xxx fault		
002. 03-17 15:08:20 xxx fault		
...		
Return	Home	Clear

Figure B-43 Real-time alarm interface

When you need to clear real-time alarm records, you can press  **Clear** and enter a correct user password to clear the records.

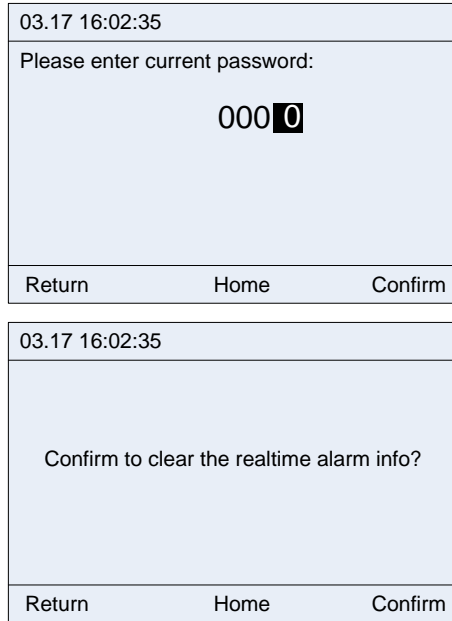

Figure B-44 Alarm record clearing interface

**Note:** The real-time alarm interface can keep a maximum of 120 fault records due to the restriction of memory. If you want to save new records, you need to manually clear the existing records or re-power on the keypad.

**B.1.5.4 Historic alarm interface**

The fault information in the historic alarm interface is the same as that in the real-time alarm interface. The only difference is that the historic alarm interface always keeps the fault records even if the keypad is powered off, while the real-time alarm interface clears all the fault records if the keypad is powered off.

**Note:** The historic alarm interface can keep a maximum of 1000 fault records due to the restriction of memory. If you want to save new records, you need to manually clear the existing records

**B.1.6 VFD information**

Enter the VFD information interface through the main menu.

03.17 16:02:35 VFD information		
<b>Master</b> ▶		
Fan		
Return	Home	Select

Figure B-45 VFD information interface

03.17 16:02:35 Master VFD info		
<b>Ctrl Board Software Ver</b> xxx.xx ▶		
Present Temperature	xxxx.x	
Digital Input Terminal State	xxxxxx	
Digital Output Terminal State	xxxxxx	
Analog P1	xxx.xx V	
Analog PT1	xxx.xx V	
Return	Home	
Analog P2	xxx.xx V	
Analog PT2	xxx.xx V	
<b>Air Compressor Ctrl Mode</b> Invalid ▶		
Return	Home	

Figure B-46 Master VFD information

03.17 16:02:35 Fan VFD info		
<b>Ctrl Board Software Ver</b> xxx.xx ▶		
Inverter Module Temp	xxxx.x	
Master Send Ctrl Cmd	xxxxxx	
Master Send Freq	xxxxxx %	
Return	Home	

Figure B-47 Fan VFD information

**Note:**

- ✧ Fan VFD information can be information only about Goodrive300-21 series VFD.
- ✧ VFD information is read only.

**B.1.7 System configuration**

Enter a correct factory password to enter the system configuration interface.

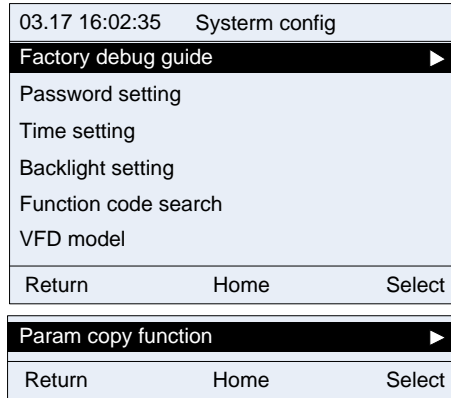

Figure B-48 System configuration interface

**B.1.7.1 Factory commissioning wizard**

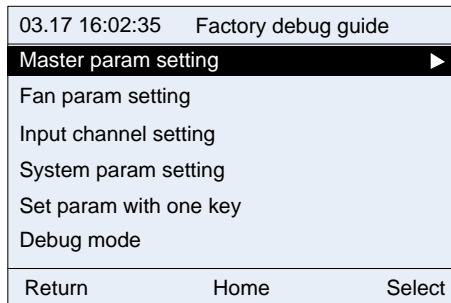

Figure B-49 Factory commissioning wizard interface

**Factory commissioning procedure**

Step 1 Enter the master parameter setting interface.

Set motor parameters according to the motor nameplate. Perform motor parameter identifying. Enter motor parameters for motor variable-frequency commissioning. Parameter autotuning is located at the last line in the master parameter setting interface, as shown in Figure B-50.

03.17 16:02:35		Master param setting	
Motor type	AM	▶	
Max frequency	050.00 Mpa		
Rated power	0090.0 kW		
Rated frequency	050.00 Hz		
Rated voltage	000380 V		
Rated current	0176.0 A		
Return	Home	Edit	

03.17 16:02:35		Master param setting	
Stator resistor	00.030 Ω		
Rotor resistor	00.025 Ω		
Leakage inductance	00.006 mH		
Mutual inductance	00.169 mH		
No-load current	0040.8 A		
Param auto-tuning		▶	
Return	Home	Edit	

Figure B-50 Master parameter setting interface

Step 2 Enter the system parameter setting interface.

According to the sensor configuration, set the pressure sensor parameters, temperature sensor parameters, and oriented function parameters. Then return to the system configuration interface.

03.17 16:02:35		System param setting	
Max voltage limit	xxxx.x %	▶	
Uplimit freq press drop	xxx.xx MPa		
Temp sensor channel	PT1		
Power correct coeffi	xxxxxx %		
Uplimit freq drop rate	xxx.xx Hz		
Press sensor P1 uplimit	xxx.xx MPa		
Return	Home	Edit	

Maintain Timeout	xxxxxx h		
Press sensor channel	P1		
Press sensor P2 Uplimit	xxx.xx MPa	▶	
Return	Home	Edit	

Figure B-51 System parameter setting interface

Step 3 Press the **Set up Parameters** key to automatically set parameters.

Step 4 Enter the commissioning mode. Run the master and fan in jogging mode to check the motor rotation direction.

Step 5 Adjust user parameters, factory parameters, and maintenance parameters according to the manual.

During commissioning, if a signal exception occurs, check VFD information to view the signal status and handle the exception.

### B.1.7.2 Date and time display

Generally, the date and time in the format of *AA.BB aa:bb:cc* is displayed in the upper left corner of the keypad interface. In the format, *AA* indicates month, *BB* indicates date, *aa* indicates hour, *bb* indicates minute, and *cc* indicates second. For example, the "03.17 16:02:35" in the following figure indicates the current time is 16:02:35 on March 17.

**Note:** The real-time clock function can be used properly only when batteries are available. The battery compartment is located on the back of the keypad. You only need to remove the lid to check whether batteries are available.

03.17 16:02:35	Workspace	Ready
Output Freq P17.01 Hz	0.00	
Present Pressure P19.11 Mpa	0.00	
Present Temp P19.12 °C	25	
Alarm	Set	Menu

### B.1.7.3 Password setting

The controller provides multi-level password and permission management. The mapping between passwords and permissions is as follows:

- User password: able to modify user password and clear fault records.
- Administrator password: able to modify maintenance parameters, protection parameters, master parameters, and fan parameters, in addition to the permissions with a user password.
- Factory password: able to modify all parameters.
- Super factory password: able to modify all parameters.

Passwords are changeable. To change a password, enter the password correctly, enter a new password, and then re-enter the new password for confirmation. The password can be changed successfully only when no errors are made.

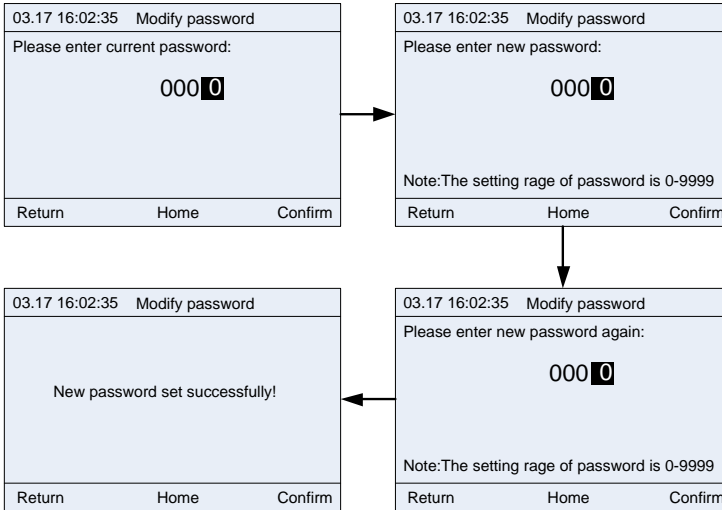



Figure B-52 Password changing interface

**B.1.7.4 Date and time setting**

If the keypad time is incorrect, you can change the time in the date and time setting interface. The year setting range is 2000–2099.

You can move the black cursor leftward or rightward through the keypad, adjust the digits through the

Up or Down key, and then press  to confirm the change.

**Note:** Ensure that batteries have been installed in the back of the keypad.

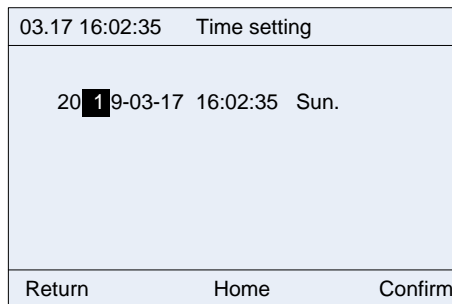

Figure B-53 Date and time setting interface

**B.1.7.5 Screen backlight setting**

The LCD keypad backlight setting includes the backlight brightness and time.

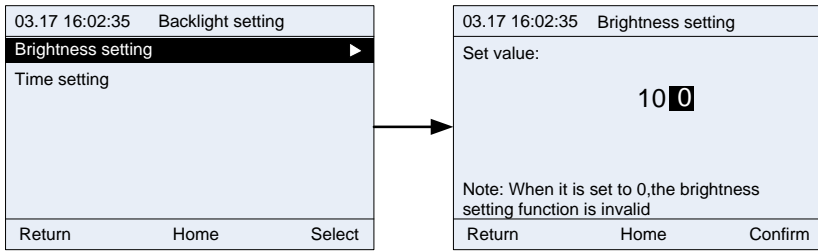

Figure B-54 Screen backlight brightness setting interface

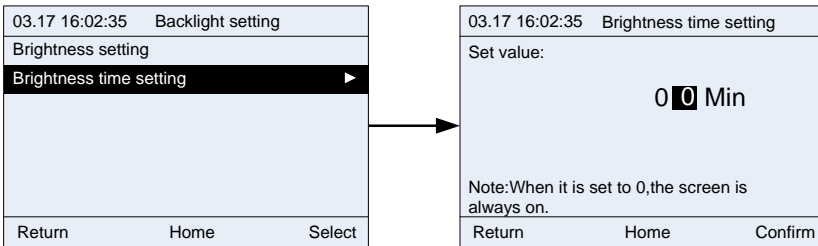

Figure B-55 Screen backlight time setting interface

**B.1.7.6 Function code searching**

The function code searching interface allows you to query and modify all VFD function codes. Figure B-56 shows an example of how to query and modify P00.04.



Figure B-56 Function code searching interface

**B.1.7.7 VFD model selection**

This interface allows you to select the VFD model. Different VFD models may be different in the function codes.

When communication is proper, the keypad automatically identifies the VFD model. In certain cases, you need to manually select the VFD model.

For example, when the connected VFD is Goodrive300-21, and the dual-VFD integrated machine contains the master and fan, the keypad identifies Goodrive300-21 (master) by default. In this case, if you want to check the function codes of the fan VFD, you need to manually switch to the fan VFD.

**Note:** After you search fan VFD function codes and return to the main menu interface, the keypad will automatically identify the master VFD again.

Figure B-57 lists the supported VFD series. In future, more VFD series may be supported.

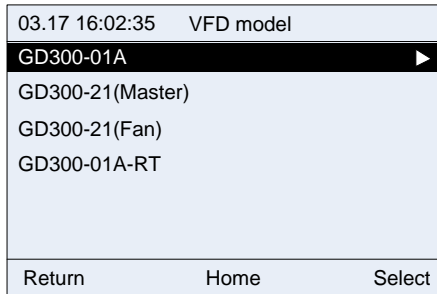

Figure B-57 VFD model selection interface

**B.1.7.8 Parameter copying**

The parameter copying function allows you to upload parameters from the connected VFD to the keypad and also allows you to download parameters from the keypad to the connected VFD.

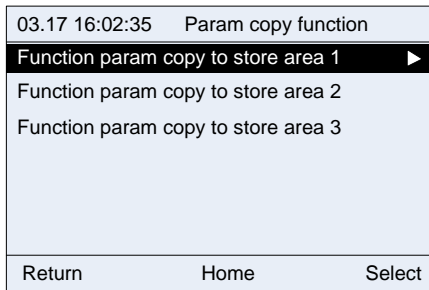



Figure B-58 Parameter copying function 1

Each storage area supports parameter upload, parameter download 1 (all parameters), parameter download 2 (non motor parameters), and parameter download 3 (only motor parameters). After you

press  for confirmation, the corresponding operation is performed.

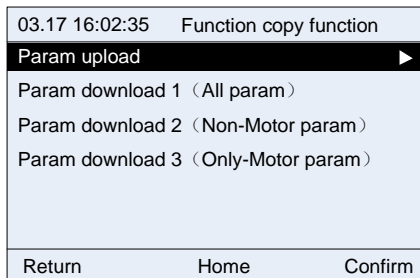

Figure B-59 Parameter copying function 2

## B.2 TC070A touch screen

### B.2.1 Specifications

Table B-4 Touch screen specifications

Category	Item	Specifications
Hardware category	Screen	7" 16:9 TFT LCD screen
	Resolution	800x480
	Color	24 bits
	Brightness	360 cd/m <sup>2</sup>
	Backlight	LED
	LCD lifetime	50000 hours
	Touch screen	4-wire industrial resistance touch screen
	CPU	600MHz ARM Cortex-A8
	Memory	128M Flash + 128M DDR3
	RTC	Real-time clock (embedded)
	Ethernet	None
	USB port	1 USB Slave 2.0 port; 1 USB Host 2.0 port
	Program download method	USB Slave/U disk
	Serial communication port	COM1: RS232/RS485/RS422 COM2: RS485 COM3: RS232
Viewing angle of LCD (T/B/L/R)	50°/70°/70°/70°	
Electrical performance	Rated power	< 10W
	Rated voltage	DC24V, allowable working range DC 9V–28V
	Power supply protection	Surge protection capability
	Allowed power outage	< 5mS
	CE & RoHS	Compliant with EN61000-6-2 and EN61000-6-4 Compliant with RoHS lightning surge ±1kV, group pulse ±2kV Static contact 4kV, air discharge 8kV
Environment requirement	Working temperature	0–50°C
	Storage temperature	-20–60°C
	UV resistance	Disallowed to work under strong UV (such as direct sunlight)

Category	Item	Specifications
	Ambient humidity	10–90%RH (no condensation)
	Shock resistance	10–25Hz (X, Y, Z direction 2G/30 minutes)
	Cooling method	Natural air cooling
Mechanical performance	IP rating	The front panel reaches IP65 (installed with a flat panel cabinet), and the rear shell of the device reaches IP20.
	Mechanical structure	Engineering plastic
	Cut-out dimensions	192mm×138mm
	Overall dimensions	204mm×145mm×33.8mm
	Overall weight	About 560g

Table B-5 Touch screen ordering description



Item	Description	Order No.
TC070A touch screen	Includes the RS485 communication cable, 24V power cable, and emergency stop cable, each of which is 2.5-meter long.	11026-00011
Communication function module	Communication mode GPRS, plug directly	34008-00097

**Note:** Users can choose the optional INVT ICA200 series IoT module. For details, refer to section B.3.

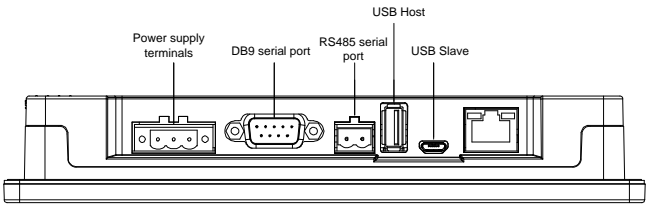
**B.2.2 Connection terminals**

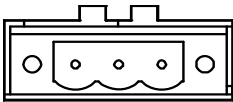
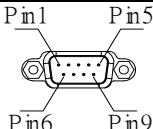

Power supply terminals (Pins 1–3, from left to right)		
	Pin1	FG
	Pin2	0V
	Pin3	DC24V
DB9 serial port terminals		
	Pin1	Rx-(B)
	Pin2	RxD (COM1 RS232)
	Pin3	TxD (COM1 RS232)
	Pin4	Tx-

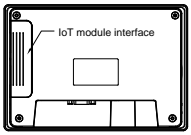
	Pin5	GND
	Pin6	Rx+(A)
	Pin7	RxD (COM3 RS232)
	Pin8	TxD (COM3 RS232)
	Pin9	Tx+
<b>RS485 terminals (Pins 1–2, from left to right)</b>		
	Pin1	A+ (COM2 RS485)
	Pin2	B- (COM2 RS485)
<b>USB Host</b>		
	USB Type A	Used to connect external peripherals such as the USB disk and barcode scanning device
<b>USB Slave</b>		
	MicroUSB	Used for program download and debugging
<b>FLink expansion module</b>		
	Expansion module slot	Supported modules: FLink, FLink-2G, FLink-4G, and FLink-WiFi

**B.2.3 Wiring description**

In order to drive and manage the air compressor better, use the provided RS485 communication cable, of which one end is connected to the touch screen power supply port and DB9 serial port and the other is connected to Goodrive300-01 VFD control board terminal (CN 7).

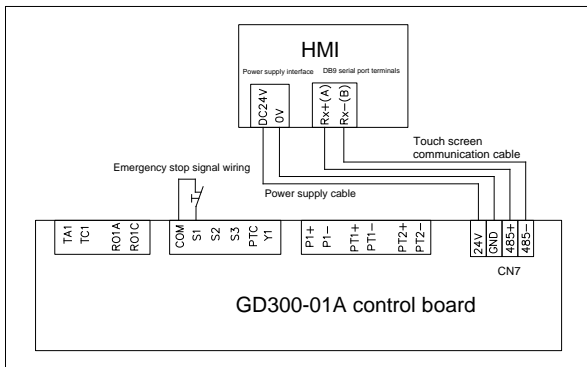

Figure B-60 Standard touch screen wiring diagram

**B.2.4 Cable description**

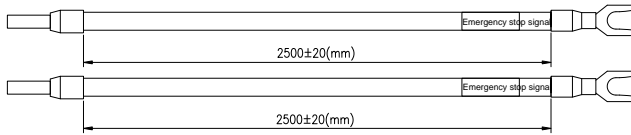

Figure B-61 Emergency stop cable diagram

**Note:** The emergency stop cable is used for emergency stop control when a device fault occurs and it is often connected to the S1 terminal and COM terminal.

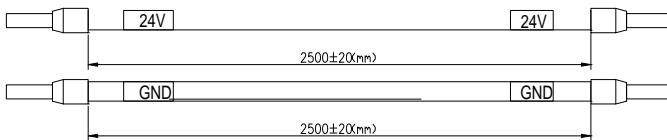

Figure B-62 Touch screen power supply cable diagram

**Note:** As shown in Figure B-60, the touch screen power supply interface is connected to CN7 of GD300-01A VFD control board.

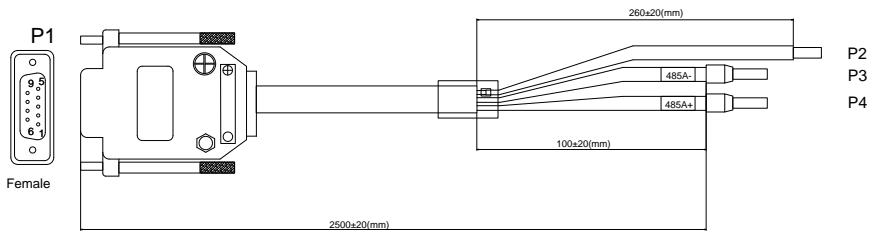

Figure B-63 Touch screen communication cable diagram

Terminal diagram	Terminal		Cable	
<p>P1 Female</p>	P1(1PIN)	RX-(B)	P3	485-
	P1(6PIN)	RX+(A)	P4	485+
	Iron shell		P2	Shield layer grounding cable

**B.2.5 Installation dimensions and description**

**B.2.5.1 Touch screen installation dimensions**

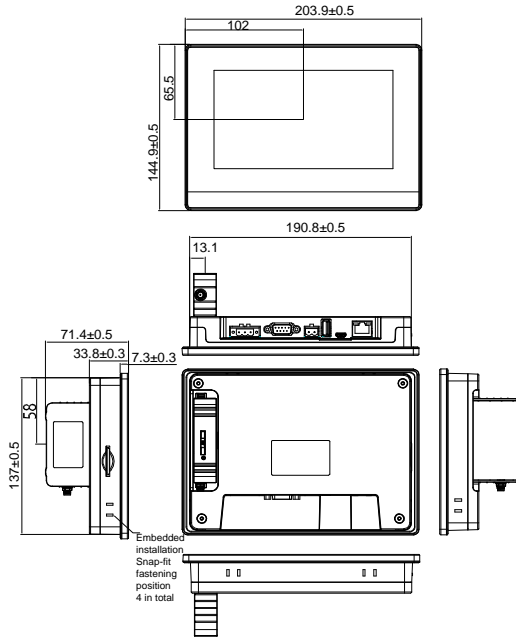
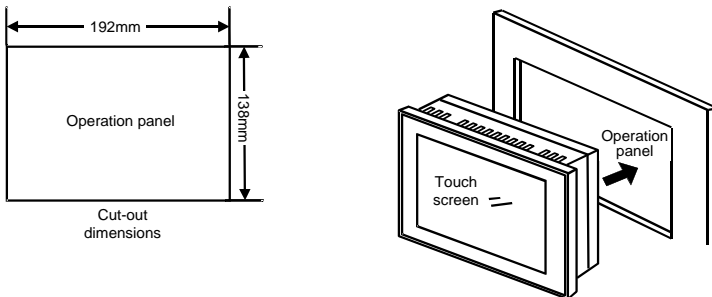

Figure B-64 Touch screen installation dimensions (unit: mm)

**B.2.5.2 Cut-out installation description**

When you want to build the touch screen into the operation panel of the control cabinet, use the cross screwdriver and metal installation snap-fit. The installation procedure is as follows:

Step 1 Cut a rectangular installation groove on the operation panel of the control cabinet according to the cut-out dimensions, and then insert the touch screen from the front of the operation panel.



Step 2 Insert the metal snap-fits into the back, top and bottom mounting jacks of the touch screen, insert the fastening screws (attached), and then tighten the screws with the cross screwdriver.

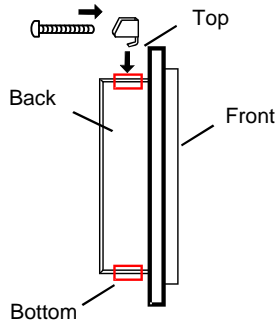

## B.3 IoT module

### B.3.1 Product overview

INVT ICA series communication adapter is a kind of wireless data terminal for Internet of Things (IoT), which provides users with wireless long-distance data transmission function through the public operator network.



a) Wall-mounted

b) Rail-mounted

Figure B-65 Pictures of ICA200 communication adapter

#### B.3.1.1 Product features

Reliable design:

- ✧ Adopt WDT watchdog design to guarantee system stability;
- ✧ Adopt anti-offline mechanism to ensure data terminal is always online.
- ✧ RS232/RS485 interface with built-in 15kV ESD protection;
- ✧ SIM/UIM card interface with built-in 15kV ESD protection;
- ✧ Power interface with built-in phase reversal and over-voltage protection.

Standard set-up for easy operation:

- ✧ With standard RS485 interface for direct connection with serial device;
- ✧ Intelligent data terminal which enters data transmission status at power-on;
- ✧ Powerful central management software for easy device management (optional);
- ✧ Convenient system configuration and maintenance interface.

Powerful function:

- ✧ With standard RS232 interface and support local serial software upgrade.
- ✧ Support remote wireless update and policy configuration.
- ✧ With built-in standard TCP/IP protocol stack to support transparent data transmission.
- ✧ Support APN.
- ✧ Can be directly connected with serial device; support 1 adapter to 8 terminal devices collection with each device supporting 40 groups of Modbus register collection; set with terminal resistor switch, which is safe and reliable against interference.
- ✧ Convenient system set-up and maintenance interface for flexible set-up of remote server IP, port number, etc.
- ✧ Inquiry address and collection cycle of Modbus is configurable, only changed data will be transmitted to save traffic in data upload.
- ✧ Support GPRS base station positioning.
- ✧ GPS satellite positioning for acquiring accurate device location in real-time (optional).

**B.3.1.2 Model instruction**

Model name illustration of INVT communication adapters for the IoT:

**ICA 2 0 0-0 0 G-5**  
 ①      ②   ③   ④   ⑤   ⑥   ⑦   ⑧

Field	Symbol	Description	Content
Abbreviation for product series	①	Abbreviation for product series	ICA is the abbreviation for Internet Communication Adapter
Wireless communication	②	Communication type	2: GPRS
Wired communication	③	Communication type	0: Do not support wired communication
Local data collection mode	④	Collection communication mode	0: RS485
Monitoring object	⑤	Max. number of access points	0: Single 2: 4 units 3: 8 units

Field	Symbol	Description	Content
Protection level	⑥	Protection level	0: IP00 (No housing); 1: IP20 (wall-mounted housing); 2: IP20 (rail-mounted housing); 6: IP65 (direct-insert housing).
Special function	⑦	Special function (multiple letters are supported)	G: With GPS Standard configuration does not carry GPS function, this bit is omitted
Voltage type	⑧	Supply voltage	5: 4.5V–6V Standard configuration voltage is 10–30V, this bit is omitted.

### B.3.1.3 Product specification

Category	Name	Detailed instruction
Basic functions	Network status detection	Detect online status automatically and reconnect at offline.
	Device working status indicator	Indicates the device working status by power and network status indicators. 1: The network status indicator turns off every 800ms (flashes slowly) if network is not registered. 2. The network status indicator turns off every 3s if network is registered. 3. The network status indicator turns off every 300ms (flashes quickly) if GPRS is connected.
	Communication protocol	IoT communication protocol; PPP dial protocol; FTP transmission protocol; Embedded TCP/UDP protocol.
	Remote update	Auto remote update on system programs via GPRS
	Communication interface	Support RS232 commissioning output; RS485 one-to-many front-end device collection; GPRS wireless transmission.
	Parameter setup	Serial baudrate, data bit, stop bit and checkout bits of Modbus device are configurable.
	Software watchdog	Monitor system running status in real-time.
	GPRS heartbeat mechanism	Monitor server connection in real-time.
	GPRS communication command	Enhance AT command set
System	Operating system	Preemptive multi-tasking real-time kernel

Category	Name	Detailed instruction
resources	CPU	ARM 32-bit Cortex™-M3 CPU
	FLASH	512KB flash
	SRAM	64KB
	Peripheral interface	RS232; RS485; GPRS; GPS;
Wireless parameters	Wireless module	Industrial-level wireless module
	Standards and frequency bands	Support four frequencies of GSM850/900/1800/1900MHz <ul style="list-style-type: none"> <li>•GPRS multi-slot class 12/10</li> <li>•GPRS mobile station class B</li> <li>•Comply with GSM 2/2+ standard</li> </ul> – Class 4 (2W @ 850/900 MHz) – Class 1 (1W @ 1800/1900MHz)
	Theoretical bandwidth	GPRS class 12: Max.: 85.6 kbps (downstream rate)
	Emission power	<28dBm
	Receipt sensitivity	<-107dBm
Interface type	Serial port	One RS232 and one RS485 interfaces with built-in 15kV ESD protection, the serial parameters are as below; Data bit: 8; Stop bit: 1; Checkout: No checkout, even parity, odd parity, SPACE and MARK checkout. Serial speed: 110–115200bits/s
	Indicator	Power indicator; Network status indicator.
	Antenna interface	Standard SMA female antenna interface with 50Ω characteristic resistance
	SIM/UIM card interface	Standard slide-in SIM card interface (IP20), clamshell Micro SIM card interface (PI00) for 1.8V/3V SIM/UIM card with 15kV ESD protection.
Power dissipation	Communication status	100mA@24VDC    200mA@12VDC    400mA@5VDC
	Transient peak current	400mA@24VDC    800mA@12VDC    2000mA@5VDC
Protection degree	Housing	IP20 (metal housing) IP00 (No housing)
Other parameters	Operating temperature	-25–+60 °C (-13–+140°F)
	Storage temperature	-40–+85 °C (-40–+185°F)
	RH	93% (No condensation)

**B.3.2 Installation dimensions**

Only properly installed adapter can achieve designed functions. The adapter must be installed by qualified electricians recognized by our company.

**Note:** The adapter must be installed with power off.

◇ Below is the outline dimension for IP00 model (no housing) (unit: mm).

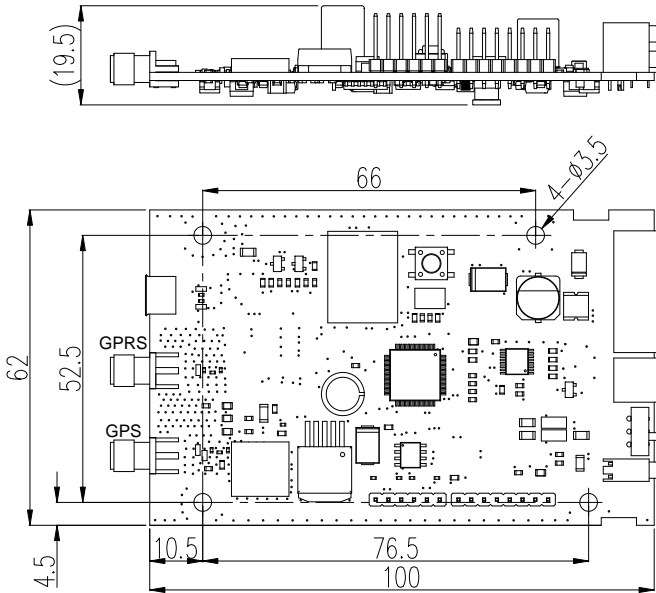

Figure B-66 Outline dimension for IP00 model

◇ Below is the outline dimension for IP20 model (wall-mounted housing) (unit: mm).

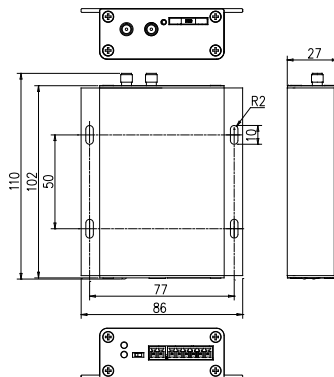

Figure B-67 Outline dimension for IP20 model (wall-mounted housing)

◇ Below is the outline dimension for IP20 model (rail-mounted housing) (unit: mm).

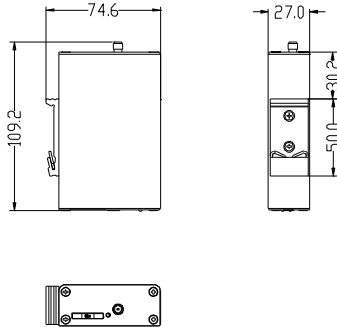

Figure B-68 Outline dimension for IP20 model (rail-mounted housing)

**B.3.3 Operational guide**

The module is usually applied in complicated environment. To cope with the complex application conditions and ensure system stability, the power must be above 3W and in stable status (the ripple is under 100mA).

For details, refer to the operation manual of *ICA Series GPRS Communication Adapter*.

**B.3.4 Ordering information**

Name	Description	Order No.
ICA200-2G	Includes GPS, rail-mounted	11023-00090
SIM card	Used for INVT communication adapter	34016-00004

Deliverables for GPRS communication adapter

Deliverables	Qty	Remark
Adapter	1	
Instruction manual	1	
GPRS antenna	1	
GPS antenna	1	Optional
Connection terminal	2	One 6PIN connection terminal and one 2PIN connection terminal

## B.4 Fan control protector

### B.4.1 Model instruction

# MCP100 - 015

①                      ②                      ③

Field	Symbol	Description	Content
Category	①	Product series	MCP: Fan protection controller
Model	②	Type of current feedback	100: Basic (digital feedback) 120: Enhanced (current analog feedback)
Protection current	③	Current class	015: Rated current is 1.5A 1000: Rated current is 10A

**Note:** Only model MCP120-1000 is available for the MCP120 series.



Figure B-69 Pictures of fan protection controller

### B.4.2 Rated specifications

Product model	Rated current (A)	Type of current feedback
MCP100-015	1.5	Digital feedback
MCP100-1000	10	Digital feedback
MCP120-1000	10	Current analog feedback

### B.4.3 Terminal description

Category	Terminal sign	Name	Terminal function
POWER	R, S, T	3PH AC input	Power frequency input, connected to the grid
MOTOR	U, V, W	3PH AC output	Power frequency output, connected to the motor
Power supply	24V	24V power supply	Provide 24V power supply to the fan control protector

Category	Terminal sign	Name	Terminal function
	GND	Reference ground	24V, RLY, CTA/Y1, CTB, CTC reference ground
Digital input	RLY	Digital input	<p>Fan start/stop control terminal</p> <p>1. When start/stop of the fan is controlled by Y terminal, cut off the fan output when the VFD Y output signal is valid and connect the fan when the VFD Y output signal is invalid. When the fan protection module reports OC fault, the Y output signal needs to be set to be valid and then set to be invalid for resetting.</p> <p>2. When start/stop of the fan is controlled by the NC output terminal of the control board relay RO3, cut off the fan output when RO3 is switched on and connect the fan output when RO3 is switched off.</p>
Current signal and overcurrent signal output	CTA/Y1	Fan overcurrent signal output	<p>It is only applicable to MCP100, OC gate output, 50mA/30V (max. value), connect to the digital input S terminal.</p> <p>Normal: Low electrical level Overcurrent: High electrical level</p>
		Fan phase A current output	<p>They are only applicable to MCP120.</p> <p>Internal current transformer ratio: 1000:5</p> <p><b>Note:</b> Disable open circuit when terminals are used.</p>
	CTB	Fan phase B current output	
	CTC	Fan phase C current output	
Jumper terminal	J1	Overcurrent threshold selection terminal	It is only applicable to MCP100. Short connect B1 to B2 by default, For details, refer to Table B-6.

Table B-6 Overcurrent threshold selection

Model	No short connection	Short connect B1 to B2	Short connect B2 to B3
MCP100-015	0.45A	1A	1.5A
MP100-1000	2.5A	3A	10A

**Note:**

1. The rated current of the fan protection module must be greater than the rated current of the fan.
2. The rated current of the fan cannot exceed 10A due to the limitation of the load carrying capacity of the fan protection module.
3. The overcurrent threshold in the above table is 50Hz sine wave RMS value. When the sine wave peak is reached, the protection starts.
4. The starting current of the fan is generally 6-8 times its rated current, the time is very short, so it will not affect the VFD or the power grid. When the fan starts at power frequency, the overcurrent protection will not act. When fan starts with exceptions and the starting current is more than 10 times its rated current, the overcurrent protection acts.

**B.4.4 Wiring description and commissioning instruction****B.4.4.1 Instruction for using GD300-01A with MCP100**

Figure B-70 Wiring for MCP100+GD300-01A

After completing the wiring according to Figure B-70, set the following parameters in the VFD.

1. P05.01=9, S1 terminal is set to external fault input.
2. P05.10=0x001, S1 polarity setting.
3. P06.02= 29, cooling fan control of main motor. Start/stop of the fan is controlled by NC contact of the VFD relay RO3.

The MCP100 overcurrent threshold can be selected by the jumper, and the specific parameter configuration is shown in Table B-6. After MCP100 reports overcurrent, the RLY signal needs to be set to be valid and then set to be invalid for resetting, that is, to unblock the relay (Press the keypad reset key on the VFD and then press the run key). If a short circuit occurs, the fuse inside MCP100 will be

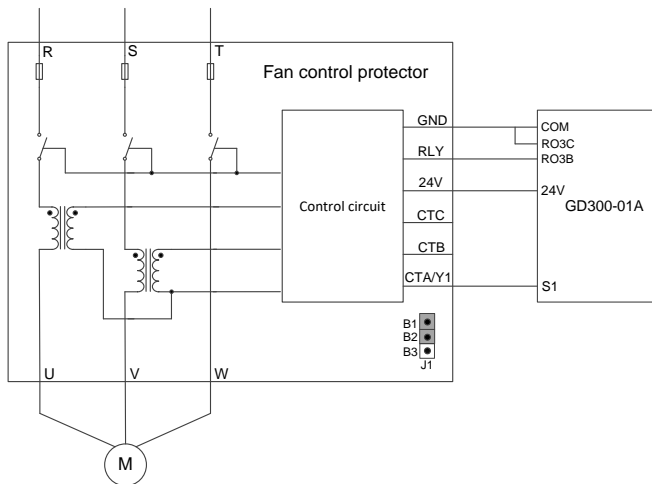
blown and needs to be replaced before it can be used again. When overcurrent is triggered, the fault signal is sent to the VFD through the S1 terminal, and the VFD stops and shuts down the fan through RO3.

**B.4.4.2 Instruction for using GD300-01A with MCP120**

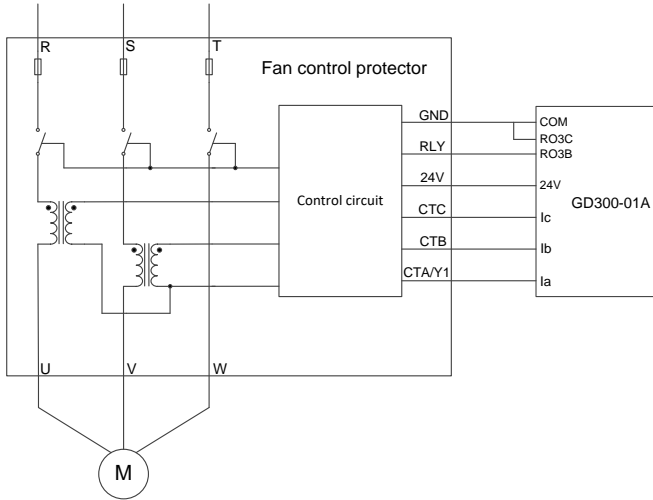

Figure B-71 Wiring for MCP120+GD300-01A

After completing the wiring according to Figure B-71, set the following parameters in the VFD.

1. P21.01= 1000.
2. Set P21.00 to the corresponding fan rated current. For example, set 2A to be 2.00.
3. P06.02= 29, cooling fan control of main motor. Start/stop of the fan is controlled by NC contact of the VFD relay RO3.

The fan current detection signals of MCP120-1000 are connected to three signal terminals (Ia, Ib and Ic) on GD300-01A control board, and start/stop of the fan is controlled by NC contact of the VFD relay RO3. The fan current signal can be read through the VFD keypad. You can view the fan overcurrent protection function setting in the P6 group and P21 group settings.

**B.5 Filter**

Filter model selections for GD300-01A are shown below.

VFD model	Input filter	Output filter
GD300-01A-7R5G-4	FLT-P04032L-B	FLT-L04032L-B
GD300-01A-7R5G-4-CT		
GD300-01A-011G-4		
GD300-01A-011G-4-CT		
GD300-01A-015G-4	FLT-P04045L-B	FLT-L04045L-B

VFD model	Input filter	Output filter
GD300-01A-015G-4-CT		
GD300-01A-018G-4		
GD300-01A-022G-4	FLT-P04065L-B	FLT-L04065L-B
GD300-01A-030G-4		
GD300-01A-037G-4	FLT-P04100L-B	FLT-L04100L-B
GD300-01A-045G-4		
GD300-01A-055G-4	FLT-P04150L-B	FLT-L04150L-B
GD300-01A-075G-4		
GD300-01A-090G-4	FLT-P04240L-B	FLT-L04240L-B
GD300-01A-110G-4		
GD300-01A-132G-4		
GD300-01A-160G-4	FLT-P04400L-B	FLT-L04400L-B
GD300-01A-185G-4		
GD300-01A-200G-4		
GD300-01A-220G-4	FLT-P04600L-B	FLT-L04600L-B
GD300-01A-250G-4		
GD300-01A-280G-4		
GD300-01A-315G-4		
GD300-01A-315G-4	FLT-P04800L-B	FLT-L04800L-B

**B.6 Reactor**

When the distance between the VFD and motor is longer than 50 meters, the parasitic capacitance between the long cable and ground may cause large leakage current, and overcurrent protection of the VFD may be frequently triggered. To prevent this from happening and avoid damage to the motor insulator, compensation must be made by adding an output reactor. When a VFD is used to drive multiple motors, take the total length of the motor cables (that is, sum of the lengths of the motor cables) into account. When the total length is longer than 50 meters, an output reactor must be added on the output side of the VFD. If the distance between the VFD and motor is 50 meters to 100 meters, select the reactor according to the following table. If the distance is longer than 100 meters, contact INVT’s technical support technicians.

Table B-7 Reactor model selection

VFD power	Input reactor	DC reactor	Output reactor
GD300-01A-132G-4	ACL2-160-4	DCL2-132-4	OCL2-160-4
GD300-01A-160G-4	ACL2-160-4	DCL2-160-4	OCL2-200-4
GD300-01A-185G-4	ACL2-200-4	DCL2-220-4	OCL2-200-4
GD300-01A-200G-4	ACL2-200-4	DCL2-220-4	OCL2-200-4
GD300-01A-220G-4	ACL2-280-4	DCL2-220-4	OCL2-280-4
GD300-01A-250G-4	ACL2-280-4	DCL2-280-4	OCL2-280-4
GD300-01A-280G-4	ACL2-280-4	DCL2-280-4	OCL2-280-4
GD300-01A-315G-4	ACL2-350-4	DCL2-315-4	OCL2-350-4

## Appendix C Current transformer of the fan

### C.1 Current transformer model selections

Power of the cooling fan (kW)	Rated current A of cooling fan	Recommended transformation ratio of the transformer
0.75	2	40A/40mA
1.1	2.7	
1.5	3.7	
2.2	5	
3	6.8	
4	8.8	
5.5	11.6	

**Note:**

- ✧ The fan can sustain tripled overload at a short-time. In order to ensure the fan can be protected by the VFD properly, the current on input side of the current transformer should be more than three times of the rated current of the fan.
- ✧ The transformation ratio of the current transformer must be 1000.

### C.2 Wiring of current transformer of the fan

The transformer should be purchased by the user. The figure below illustrates the wiring precautions for transformer. If the transformer actually used differs from the one shown in the figure below, please consult with the transformer manufacturers.

1. If users adopt 2-phase combined current transformer, please refer to the wiring diagram below.

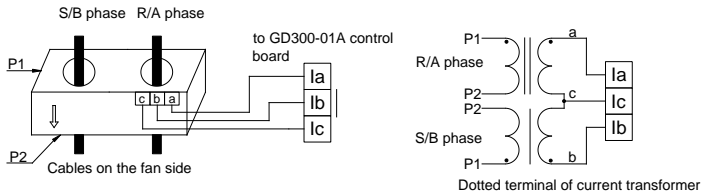

The main circuit cable must go in from P1 and out from P2. The coil a, b and c on output side of the transformer must be connected to la, lb and lc respectively. A and B must correspond to a and b respectively.

2. If users chose single current transformer, refer to the wiring diagram below.

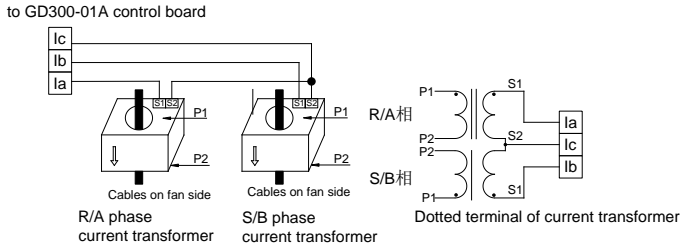

Pay attention to the current direction during wiring. P1 and S1 are dotted terminals, so does P2 and S2, namely the main circuit cable goes in from P1 and out from P2, and the S1 on output side of R/A phase must be connected to la, and S2 to lc. The S1 on output side of S/B phase must be connected to lb, and S2 to lc.

**Note:**

- ◇ Open circuit is not allowed on output side;
- ◇ Avoid large power and interference during transformer wiring;
- ◇ Wiring of the transformer and control board can be carried out only after power off.

**C.3 Parameter setup of current transformer of the fan**

1. The transformation ratio of the current transformer used by the user must be 1000. For instance, if the current on input side is 40A, current on output side must be 40mA.
2. After confirming transformer model, input the rated current value of the cooling fan.

## Appendix D Communication protocol

### D.1 Application mode

The Modbus protocol of this VFD is RTU mode and the network line is RS485.

The interface of RS485 works on semiduplex and its data signal adopts differential transmission mode which is also called balance transmission, too. It uses twisted pairs, one of which is defined as A (+) and the other is defined as B (-). Generally, if the positive electrical level sending between drive A and B is among +2 to +6V, it is logic“1”, if the electrical level is among -2V to -6V; it is logic“0”.

485+ on the VFD terminal board corresponds to A and 485- to B.

Communication baud rate (P14.01) means the binary bit number transmitted in one second. The unit is bit/s (bps). The higher the baud rate is, the quicker the transmission speed is and the weaker the anti-interference is. If the twisted pairs of 0.56mm (24AWG) is used as the communication cables, the max. Transmission distance is as below.

Baud rate (bps)	Max. transmission distance	Baud rate (bps)	Max. transmission distance
2400	1800 m	9600	800 m
4800	1200 m	19200	600 m

It is recommended to use shield cables and make the shield layer as the grounding lines during RS485 remote communication.

In the cases with less devices and shorter distance, it is recommended to use 120Ω terminal resistor as the performance will be weakened if the distance increases even though the network can perform well without load resistor.

### D.2 RTU command code and communication data

#### D.2.1 Command code: 03H, read N words (N≤16)

Command code 03H means that if the master read data from the VFD, the data number depends on the “data number” in the command code. The max number is 16 and the parameter address to be read must be continuous. The length of every data is 2 bytes (one word). The following command format is illustrated in hex (a number with “H” means hex) and one hex number occupies one byte.

This command code is used to read the working state of the VFD.

#### D.2.2 Command code: 06H, write one word

This command means the master writes data to the VFD and one command can write one data only. It is used to change the parameter and working mode of the VFD.

#### D.2.3 Command code: 08H, diagnosis function

Meaning of sub-function codes

Sub-function Code	Description
0000	Return to inquire information data

### D.2.4 Definition of data address

The address definition of communication data is used to control VFD operations, obtain VFD state information and set function parameters.

#### D.2.4.1 Rules for presentation of function code address

The parameter address occupies 2 bytes with the most significant byte (MSB) in the front and the least significant byte (LSB) in the behind. The ranges of the MSB and LSB are: MSB—00 – ffH; LSB—00 – ffH. The MSB is the group number before the radix point of the function code and the LSB is the number after the radix point, but both the MSB and the LSB should be converted into hex. For example P05.06, the group number before the radix point of the function code is 05, then the MSB of the parameter is 05, the number after the radix point is 06, then the LSB of the parameter is 06, and the function code address is 0506H in hex. Similarly, the parameter address of P10.01 is 0A01H.

#### D.2.4.2 Address description of other Modbus functions

The address definition of communication data is used to control VFD operations, obtain VFD state information and set function parameters.

Table D-1 Other function parameters

Function description	Address definition	Data meaning	R/W attribute
Communication control command	2000H	0001H: forward running	R/W
		0002H: reverse running	
		0003H: forward jogging	
		0004H: reverse jogging	
		0005H: stop	
		0006H: coast to stop	
		0007H: fault reset	
		0008H: jogging stop	
Address of the set value of communication	2001H	The set communication frequency (0–Fmax (unit: 0.01Hz))	R/W
	2002H	PID reference, range (0–1000, 1000 corresponds to 100.0%)	R/W
	2003H	PID feedback, range (0–1000, 1000 corresponds to 100.0%)	R/W
	2004H	The set torque value (-3000–3000, 1000 corresponds to 100.0% rated motor current)	R/W
	2005H	The set value of upper limit frequency of forward rotating (0–Fmax (unit: 0.01Hz))	R/W
	2006H	The set value of upper limit frequency of reverse rotating (0–Fmax (unit: 0.01Hz))	R/W
	2007H	Upper limit torque of electromotion torque (0–3000, 1000 corresponds to 100.0% motor current of the VFD)	R/W

Function description	Address definition	Data meaning	R/W attribute
	2008H	Upper limit torque of brake torque (0–3000, 1000 corresponds to 100.0% rated motor current)	R/W
	2009H	Special control command word: Bit0–1: =00: Motor 1 =01: Motor 2 =10: Motor 3 =11: Motor 4 Bit2: =1 Torque control =0: Speed control Bit3: =1 Power consumption cleared to zero =0: Power consumption not cleared to zero Bit4: =1 Pre-excitation =0: Pre-excitation forbidden Bit5: =1 DC brake =0: DC brake forbidden	R/W
	200AH	Virtual input terminal command, range: 0x000–0x1FF	R/W
	200BH	Virtual output terminal command, range: 0x00–0x0F	R/W
	200CH	The set voltage value (used for V/F separation) (0–1000, 1000 corresponds to 100.0% rated motor voltage)	R/W
	200DH	The set value 1 of AO output (-1000–1000, 1000 corresponds to 100.0%)	R/W
	200EH	The set value 2 of AO output (-1000–1000, 1000 corresponds to 100.0%)	R/W
	200FH	BIT0: =1 running time of part 1 cleared to zero; =0: invalid BIT1: =1 running time of part 2 cleared to zero =0: invalid BIT2: =1 running time of part 3 cleared to zero =0: invalid BIT3: =1 running time of part 4 cleared to zero =0: invalid BIT4: =1 running time of part 5 cleared to zero =0: invalid BIT5: =1 device running time cleared to zero =0: invalid BIT6: =1 solenoid valve loading =0: solenoid valve unloading	R/W

Function description	Address definition	Data meaning	R/W attribute
	2010H	The set maintenance time of part 1; Range: 0–65535	W
	2011H	The set maintenance time of part 2; Range: 0–65535	W
	2012H	The set maintenance time of part 3; Range: 0–65535	W
	2013H	The set maintenance time of part 4; Range: 0–65535	W
	2014H	The set maintenance time of part 5; Range: 0–65535	W
	2015H	Running time of part 1, 0–65535	W
	2016H	Running time of part 2, 0–65535	W
	2017H	Running time of part 3, 0–65535	W
	2018H	Running time of part 4, 0–65535	W
	2019H	Running time of part 5, 0–65535	W
	201AH	Running time of the device: 0–65535	W
	201BH	Start/stop command of power-frequency fan, 0–3	W
VFD state word 1	2100H	0001H: In forward running	R
		0002H: In reverse running	
		0003H: In stopping	
		0004H: In fault	
		0005H: VFD Poff state	
		0006H: VFD pre-exciting state	
VFD state word 2	2101H	Bit0: =0: Not ready to run =1: Ready to run Bi1–2: =00: Motor 1 =01: Motor 2 =10: Motor 3 =11: Motor 4 Bit3: =0: Asynchronous motor =1: Synchronous motor Bit4: =0: Non-overload pre-alarm =1: Overload pre-alarm Bit5– Bit6: =00: Keypad control =01: Terminal control =10: communication control	R
VFD fault code	2102H	See fault type	R
VFD identification code	2103H	GD300-01A-----0x012F	R

Function description	Address definition	Data meaning	R/W attribute
Running frequency	3000H	Compatible with CHF100A, CHV100 communication address	R
The set frequency	3001H		R
Bus voltage	3002H		R
Output voltage	3003H		R
Output current	3004H		R
Running speed	3005H		R
Output power	3006H		R
Output torque	3007H		R
Closed- loop setting	3008H		R
Closed- loop feedback	3009H		R
Input IO state	300AH		R
Output IO state	300BH		R
Analog input 1	300CH		R
Analog input 2	300DH		R
Analog input 3	300EH		R
Analog input 4	300FH		R
Read high speed pulse 1 input	3010H		R
Read high speed pulse 2 input	3011H		R
Read current step number of multi-step speed	3012H		R
External length value	3013H		R
External counting value	3014H		R
The set torque value	3015H		R
VFD identification code	3016H		R
Fault code	5000H		R

## D.2.5 Error message response

Table D-2 Error message response and meaning

Code	Name	Meaning
01H	Illegal command	The command from master cannot be executed. The reason maybe: 1. This command is only for new version and this version cannot realize. 2. Slave is in fault state and cannot execute it.
02H	Illegal data address.	Some of the operation addresses are invalid or not allowed to access. Especially the combination of the register and the transmitting bytes are invalid.
03H	Illegal data value	When there are invalid data in the message framed received by slave. <b>Note:</b> This error code does not indicate the data value to write exceed the range, but indicate the message frame is an illegal frame.
04H	Operation failed	The parameter setting in parameter writing is invalid. For example, the function input terminal cannot be set repeatedly.
05H	Password error	The password written to the password check address is not same as the password set by P7.00.
06H	Data frame error	In the frame message sent by the upper computer, the length of the digital frame is incorrect or the counting of CRC check bit in RTU is different from the lower computer.
07H	Written not allowed.	It only happen in write command, the reason maybe: 1. The written data exceeds the parameter range. 2. The parameter should not be modified now. 3. The terminal has already been used.
08H	Parameter cannot be modified during running	The modified parameter in the writing of the upper computer cannot be modified during running.
09H	Password protection	When the upper computer is writing or reading and the user password is set without password unlocking, it will report that the system is locked.

The slave uses function code fields and fault addresses to indicate it is a normal response or some error occurs (named as objection response). For normal responses, the slave shows corresponding function codes, digital address or sub-function codes as the response. For objection responses, the slave returns a code which equals the normal code, but the first byte is logic 1.

For example: when the master sends a message to the slave, requiring it to read a group of address data of the VFD function codes, there will be following function codes:

0 0 0 0 0 1 1 (Hex 03H)

For normal responses, the slave responds the same codes, while for objection responses, it will return:

1 0 0 0 0 1 1 (Hex 83H)

Besides the function codes modification for the objection fault, the slave will respond a byte of abnormal code which defines the error reason.

When the master receives the response for the objection, in a typical processing, it will send the message again or modify the corresponding command.

## Appendix E Common EMC problems and troubleshooting

### E.1 Interference problems of meter switches and sensors

The sensor signal (pressure, temperature, displacement, etc.) is collected and displayed via HMI device, the sensor value displayed after VFD starts is wrong, the common phenomena are listed below:

- ✧ Incorrect display of upper limit or lower limit value, such as 999 or -999;
- ✧ The displayed value changes randomly (often occurred to pressure transmitter);
- ✧ The displayed value is stable but huge deviation exists e.g. the displayed temperature value is dozens of centigrade higher than the normal value (often occurred to thermocouple);
- ✧ The signal collected by the sensor does not display directly but acts as feedback signal for drive system operation e.g. the VFD is supposed to decelerate when the air compressor has reached the upper limit pressure, however, the VFD starts to decelerate before upper limit pressure is reached;
- ✧ Various meters connected by VFD analog output (AO) (such as frequency meter, current meter, etc.), the value displayed by these meters after VFD starts is inaccurate;
- ✧ The system adopts proximity switch. The indicator of proximity switch flickers after VFD starts, overturn occurred to output level by mistake.

#### Solution

- ✧ Check and confirm the sensor feedback line is routed with motor cable at a distance of at least 20cm;
- ✧ Check and ensure motor ground line has been connected to PE terminal of the VFD (if motor ground line has been connected to the grounding bar of VFD cabinet, measure with multimeter to confirm that the resistance between grounding bar and PE terminal is less than 1.5Ω);
- ✧ If there are too many interfered meters/sensors, it is recommended to install external C2 filter at the input power side of the VFD.

### E.2 485 communication interferences

The 485 communication interference mainly lies in communication delay, out-of-synchronization, disconnection or occasional normal after VFD starts.

Abnormal communication is not always caused by interference, which can be ruled out by below means.

- ✧ Check if circuit break or poor contact occurred to 485 communication bus;
- ✧ Check if both ends of A, B cable of the 485 communication bus are connected reversely.
- ✧ Check if the communication protocol (e.g. baud rate, data bit check, etc.) of the VFD is in consistent with that of the upper PC;

If it is confirmed that the abnormality is caused by interference, rule out the problem cause by below means.

- ✧ The communication cable cannot be routed with motor cable in the same cable tray;
- ✧ In multi-machine application, the connection of communication cables between VFDs should adopt chrysanthemum mode to improve anti-interference ability;
- ✧ In multi-machine application, it is necessary to confirm that the drive capacity of the master is strong enough;
- ✧ For multi-machine connection, both ends should be connected to 120Ω terminal resistors.

**Solution:**

- ✧ Check and confirm the motor ground line is connected to PE terminal of the VFD (if motor ground line has been connected to the grounding bar of VFD cabinet, measure with multimeter to confirm that the resistance between grounding bar and PE terminal is less than 1.5Ω);
- ✧ The VFD and motor cannot be common grounded along with the communication upper PC (PLC, HMI, touch screen, etc.). It is recommended to connect the VFD and motor to the power GND, and connect the communication upper PC to the ground pile separately;
- ✧ Try to short connect reference GND terminal of VFD signal to the reference GND terminal of upper PC controller signal to ensure the ground potential of their communication chips is the same;
- ✧ Try to short connect reference GND terminal of VFD signal to the grounding terminal (PE) of the VFD.

**E.3 Unstoppable or shimmering indicator caused by coupling of motor cable****Interference phenomena:**

- ✧ Unable to stop

For VFD system whose start/stop is controlled by S terminal, the motor cable and control cable are routed in the same cable tray. After system starts, it cannot stop by S terminal.

- ✧ Shimmering indicator

After VFD starts to run, shimmering, flickering or abnormal noise occurred to below equipment:

- a) Relay indicator
- b) Indicator of distribution box
- c) PLC indicator
- d) Indicating buzzer

**Solution:**

- a) Check and confirm the abnormal signal cable is routed with motor cable motor cable at a distance of at least 20cm;
- b) Connect in parallel the digital input terminal (S) used for start/stop control with other idle digital input terminals. For instance, S1 terminal is used for start/stop control, S4 terminal is idled, then try to short connect S1 terminal with S4 terminal.

## E.4 Leakage current and residual current device (RCD)

As the VFD outputs high frequency PWM voltage to drive the motor, the distributed capacitance against the radiator from internal IGBT and between rotor and stator of the motor may cause the VFD to generate high frequency leakage current against the ground. While the RCD is used to detect the power frequency leakage current when grounding fault occurred to electrical circuit, the application of VFD may cause mal-operation of RCD.

### How to select RCD:

Due to the specialty of VFD system, it is required that the rated residual operating current should be above 200mA for regular RCDs at all levels, and the VFD must be grounded with proper technics.

As for the setting time of RCD, the time limit of preceding action should be longer than the secondary action and time gap between them should be set to a value larger than 20ms e.g. 1s, 0.5s and 0.2s.

It is recommended to use electromagnetic RCD for the electrical circuit of VFD system. Such RCD carries strong anti-interference capacity to prevent the RCD from being affected by high frequency leakage current.

Electronic RCD	Electromagnetic RCD
Low cost, high sensitivity, small size, vulnerable to voltage fluctuation of the grid and ambient temperature, weak anti-interference capacity	Require the zero sequence current transformer to be quite sensitive, precise and stable, made from permalloy material with high permeability, complicated process and high cost, immune to voltage fluctuation of the grid and ambient temperature., strong anti-interference capacity

### Solution to mal-operation of RCD (on the part of VFD)

- Try to disassemble the jumper cap in "EMC/J10" (refer to section 3.1.3 and 3.1.4 for the position of J10)
- Try to decrease the carrier frequency to 1.5kHz (P00.14=1.5);
- Try to change the modulation mode to "3PH modulation and 2PH modulation" (P8.40=00)

### Solution to mal-operation of RCD (on the part of system distribution)

- Check and confirm the power cable is not immersed in water
- Check and confirm the cable is not broken or switched over;
- Check and confirm if secondary grounding occurred to the null line;
- Check and confirm if power cable terminal is in the air switch or the contactor is poorly contacted (loose screws);
- Check the single-phase electric equipment and confirm if the ground line is misused as null line;
- VFD power cable and motor cable should not be shielded ones.

### Leakage protection of motor autotuning

During motor autotuning, the measurement on differing motor parameters is conducted step by step,

in which the first two steps is to measure the resistance of motor stator/rotor while the VFD will output square wave to motor stator winding at 4kHz (default carrier frequency), as leakage current generated by 4kHz carrier frequency against distributed capacitance between motor rotor and stator during charging/discharging is quite obvious, which may cause mal-operation of RCD. If such problem occurred, bypass RCD first and restore after parameter autotuning is completed.

### **E.5 Problem of charged device shell**

The problem mainly lies in that the device shell carries detectable voltage which gives anyone who touches it a feeling of electrical shock, however, when the VFD is powered up without running, the shell will be uncharged (or the voltage it carries is far lower than human body safety voltage).

#### **Solution:**

- a) If there is distribution grounding or ground pile on users' site, ground the shell of VFD cabinet by power GND or ground pile;
- b) If there is no grounding connection on site, it is necessary to electrically connect the motor shell to grounding terminal PE of the VFD and confirm that the jumper in "EMC/J10" of the VFD is short connected (refer to section 3.1.3 and 3.1.4 for the position of EMC/J10).



Service line: 86-755-23535967 E-mail: [overseas@invt.com.cn](mailto:overseas@invt.com.cn) Website: [www.invt.com](http://www.invt.com)

The products are owned by **Shenzhen INVT Electric Co.,Ltd.**

Two companies are commissioned to manufacture: (For product code, refer to the 2nd/3rd place of S/N on the name plate.)

**Shenzhen INVT Electric Co., Ltd.** (origin code: 01)

Address: INVT Guangming Technology Building, Songbai Road,  
Matian, Guangming District, Shenzhen, China

**INVT Power Electronics (Suzhou) Co., Ltd.** (origin code: 06)

Address: 1# Kunlun Mountain Road, Science&Technology Town,  
Gaoxin District, Suzhou, Jiangsu, China

- Industrial Automation:** ■ HMI                      ■ PLC                      ■ VFD                      ■ Servo System  
   ■ Elevator Intelligent Control System                      ■ Rail Transit Traction System
- Energy & Power:**                      ■ UPS                      ■ DCIM                      ■ Solar Inverter                      ■ SVG  
   ■ New Energy Vehicle Powertrain System                      ■ New Energy Vehicle Charging System  
   ■ New Energy Vehicle Motor



Copyright© INVT.

Manual information may be subject to change without prior notice.

202202 (V1.4)